

LG

THERMA V™

Air-to-Water Heat Pump / Monobloc

R32 / 50Hz

5BPM5-01A

TOTAL HVAC SOLUTION PROVIDER

ENGINEERING PRODUCT DATA BOOK



Iris Hellas

Technology Innovations

www.irishellas.com



P/No.:MFL66101135

THERMA VTM
Monobloc Type

General Information

Product Data

Design and installation

THERMA VTM
Monobloc Type

General Information

- 1. Model Line up**
- 2. Nomenclature**

1. Model line up

◆ **Model line up**

Category	Capacity (kW)	Chassis	Model Name
1 Phase Model 1 Ø, 220-240 V, 50 Hz	5.5	UN36A	ZHBW056A2 [HM051MRS UA40]
	7.0		ZHBW076A2 [HM071MRS UA40]
	9.0		ZHBW096A2 [HM091MRS UA40]
	12.0	UN36B	ZHBW126A2 [HM121MRS UB40]
	14.0		ZHBW146A2 [HM141MRS UB40]
	16.0		ZHBW166A2 [HM161MRS UB40]
3 Phase Model 3 Ø, 380-415 V, 50 Hz	12.0	UN36B	ZHBW128A2 [HM123MRS UB40]
	14.0		ZHBW148A2 [HM143MRS UB40]
	16.0		ZHBW168A2 [HM163MRS UB40]

◆ **External appearance**

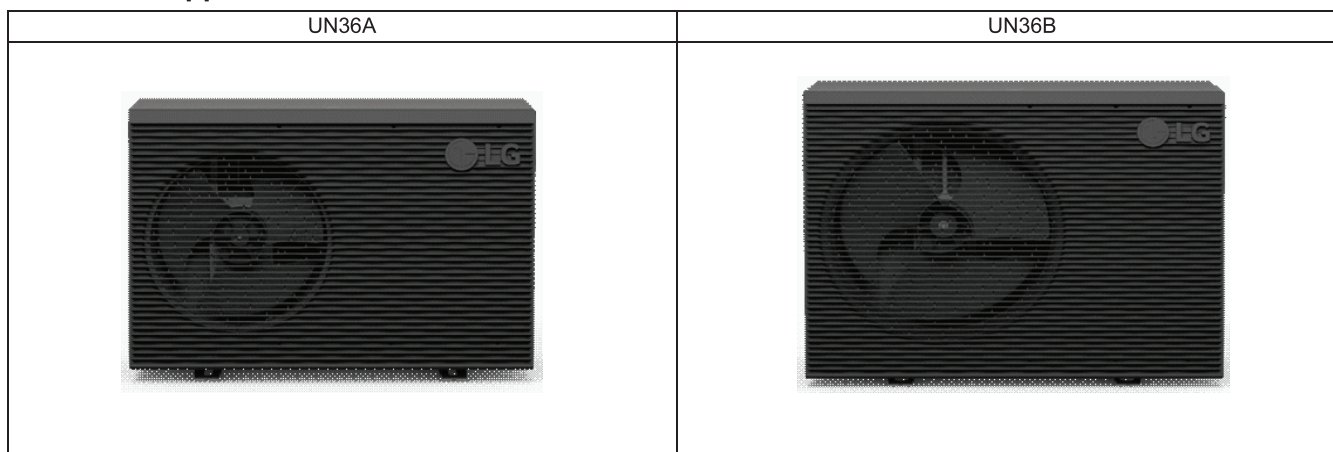

Iris Hellas
Technology Innovations
www.irishellas.com

2. Nomenclature

■ Factory Model Name

Model Name	ZH	B	W	09	6	A	2
No.	1	2	3	4	5	6	7

No.	Signification
1	ZH : Air-to-Water Heat Pump for R32
2	Classification B : Monobloc
3	Model Type W : Inverter Heat Pump
4	Heating Capacity (kW) Ex) 5 kW : '05', 16 kW : '16'
5	Electrical ratings 6 : 1 Ø, 220-240 V, 50 Hz 8 : 3 Ø, 380-415 V, 50 Hz
6	Function A : General Heating Heat pump
7	Series

2. Nomenclature

■ Buyer Model Name

Model Name	H	M	09	1	M	R	S	UA40
No.	1	2	3	4	5	6	7	8

No.	Signification
1	H : Air-to-Water Heat Pump
2	Classification M : Monobloc type
3	Heating Capacity (kW) Ex) 5 kW : '05', 16 kW : '16'
4	Electrical ratings 1 : 1 Ø, 220-240 V, 50 Hz 3 : 3 Ø, 380-415 V, 50 Hz
5	Leaving Water Combination M : Mid Temperature
6	Type of refrigerant A : R410A R : R32
7	Function S: Solo
8	Platform (Chassis code) UA40 : UN36A chassis UB40 : UN36B chassis

THERMA VTM

Monobloc Type

Product Data

- 1. List of Functions**
- 2. Specification**
- 3. Dimensions**
- 4. Piping Diagrams**
- 5. Wiring Diagrams**
- 6. Performance Data**
- 7. Electric Characteristics**
- 8. Operation Range**
- 9. Sound levels**
- 10. Hydraulic Performance**

1. List of Functions

◆ Water side

Category	Functions	
		ZHBW056A2 [HM051MRS UA40]/ZHBW076A2 [HM071MRS UA40] ZHBW096A2 [HM091MRS UA40]/ZHBW126A2 [HM121MRS UB40] ZHBW146A2 [HM141MRS UB40]/ZHBW166A2 [HM161MRS UB40] ZHBW128A2 [HM123MRS UB40]/ZHBW148A2 [HM143MRS UB40] ZHBW168A2 [HM163MRS UB40]
Installation	Backup heater (Install kit)	Accessory
	Domestic Hot Water Tank heater	Accessory
Reliability	Self diagnosis	0
Convenience	Auto Restart	0
	Child lock	0
	Sleep Timer	0
	Turn On/Off Reservation	0
	Schedule	0
	Low noise operation	0
Network	Network solution(LGAP)	0
Water Product functions	Water Pump Pre-run / Over-run control	0
	Water Pump Forced Operation	0
	Water Pump Speed Control	0
	Water Flow Detection by Flow Sensor	0
	Water Flow Control	0
	Water Pressure Monitoring	0
	Thermostat interface (230V AC)	0
	Thermostat interface (24V AC)	X
	One Point Dry Contact Input (CN-EXT)	0
	Digital output for external pump	0
	Digital inputs for energy saving (Ready for Smart Grid)	0
	Communication with LG ESS by Modbus	0
	Anti-condensation on floor (cooling)	0
	Anti-Freezing Control	0
	Anti-overheating of water pipe	0
	Emergency operation	0
	Weather Dependent Operation with Thermostat	0
	Seasonal auto mode (heating and cooling)	0
	DHW(Domestic Hot Water) tank kit	0
	Scheduler (DHW Tank Heater)	0
	Timer (Domestic Hot Water Tank Heater)	0
	Quick Domestic Hot Water Tank Heating	0
	DHW Recirculation	0
	Tank Disinfection	0
	Electric Heater Capacity Control	-
	Solar thermal Function	Accessory(3rd party)
Screed Drying Mode	0	
Current Flow Rate Monitoring	0	
Energy Monitoring	0	
Special Functions	Wi-Fi Control	Accessory
	Modbus connectivity (without gateway)	0
	Remote room temperature sensing	Accessory
	Outdoor Temperature sensing	Accessory
	2nd Circuit (Mixing Circuit)	Accessory(3rd party)
	2-Remo control	Accessory

Note

1. 0 : Applied, X : Not applied

Accessory : Ordered and purchased separately the accessory package referring to the model name provided and install at field.

Accessory line-ups varies by region, so check your local catalogue or local sales material.

2. Solar thermal system requires the 3rd party accessory, PT-1000 sensor. (field supply)

1. List of Functions

◆ Refrigerant side

Category	Functions	ZHBW056A2 [HM051MRS UA40] ZHBW076A2 [HM071MRS UA40] ZHBW096A2 [HM091MRS UA40] ZHBW126A2 [HM121MRS UB40] ZHBW146A2 [HM141MRS UB40] ZHBW166A2 [HM161MRS UB40]	ZHBW128A2 [HM123MRS UB40] ZHBW148A2 [HM143MRS UB40] ZHBW168A2 [HM163MRS UB40]
Reliability	Defrost / Deicing	O	O
	High pressure switch	O	O
	Low pressure switch	X	X
	Phase protection	X	O
	Restart delay (3-minutes)	O	O
	Self diagnosis	O	O
	Soft start	X	X
Convenience	Test function	X	X
	Low Noise Operation	O	O
	Wiring Error Check	X	X
	Peak Control(Step 1&2)	O	O
	Peak Control(Step 3&4)	X	X
	Mode Lock	O	O
	Forced Cooling Operation (Outdoor Unit)	X	X
	Base Pan Heater	O	O
SLC(Smart Load Control)	X	X	
Network	Network solution(LGAP)	O	O

Note

1. O : Applied, X : Not applied

Accessory : Ordered and purchased separately the accessory package referring to the model name provided and install at field.

Accessory line-ups varies by region, so check your local catalogue or local sales material.

2. Solar thermal system requires the 3rd party accessory, PT-1000 sensor. (field supply)

1.List of Functions

■ Accessory Compatibility List

Category	Accessory Name	Model Name	Descriptions	ZHBW056A2 [HM051MRS UA40] ZHBW076A2 [HM071MRS UA40] ZHBW096A2 [HM091MRS UA40] ZHBW126A2 [HM121MRS UB40] ZHBW146A2 [HM141MRS UB40] ZHBW166A2 [HM161MRS UB40] ZHBW128A2 [HM123MRS UB40] ZHBW148A2 [HM143MRS UB40] ZHBW168A2 [HM163MRS UB40]
Remote Controller	Wired - RS3 (Standard III)	PREMTW101	White	O
Dry Contact	Simple	PDRYCB000	1 input port, AC 220 - 240V	O
	Thermostat	PDRYCB320	8 input port, For 3rd Party Thermostat (Analog Input)	O
Integration Device	Remote Temperature sensor	PQRSTA0	Room temperature sensor, NTC 10kΩ, include casing	O
	Group Control wire	PZCWRCG3	Cable Assembly for group control (Y-type cable : 0.25m,cable : 9.6m)	X
ETC	Extension wire	PZCWRC1	Extension wire for IDU-wired remote controller (9.6m)	O
	2-Remo Control wire	PZCWRC2	Y-type cable to connect additional Remote Controller as slave	O
	Wi-Fi Modem	PWFMDD200	Device to use ThinQ app include connection cable	O
	Wi-Fi Extension cable	PWYREW000	USB Extension cable : 10 m	O
	Meter Interface	PENKTH000	Interface to connect 3rd-party heat and/or watt meter to indoor unit by S0 or Modbus	O
Special Kit	Solar-Thermal kit	PHLLA*	Limit Temperature : 96 °C	O
	IDU Drain Pan	PHDPB	For Hydro Unit	X
		PHDPC	For Hydro Unit	X
	DHW tanks (Single coil)	OSHW-200F	200 L	O
		OSHW-300F	300 L	O
		OSHW-500F	500 L	O
	DHW tanks (Double coil)	OSHW-300FD	300 L	O
	DHW Heater kit	PHLTA	For Hydro Unit and Control Unit	X
		PHLTB	For Monobloc	O
	Wall mounted outdoor air temp. sensor	PHATS0	For measuring outside temperature	O
	Thermistor for Water Tank (Buffer Tank, DHW Tank)	PHRSTA0	Included in DHW Tank kit	O
	Thermostatic Mixing valve	OSHA-MV	3/4" DN20	O
		OSHA-MV1	1" DN25	O
	3way valve	OSHA-3V	Diverting valve between space heating and DHW heating	O
	Thermistor for 2nd Circuit	PRSTAT5K10	NTC 5kΩ sensor needed to control mixing circuit or if 3rd party backup heater is used	O
	Backup Heater	HA031M E2	1Ø, 3kW (For Monobloc)	O
		HA061M E2	1Ø, 6kW (For Monobloc)	O
		HA063M E2	3Ø, 6kW (For Monobloc)	O
		HA061B E1	1Ø, 6kW (For Hydrosplit, HN1600MB NK0)	X
		HA061C E1	1Ø, 6kW (For Hydrosplit, HN1600MC NK1)	X
HA063B E1		3Ø, 6kW (For Hydrosplit, HN1600MB NK0)	X	
HA063C E1		3Ø, 6kW (For Hydrosplit, HN1600MC NK1)	X	
Cover plate	PDC-HK10	For Combi Unit and Hydro Unit Type indoor units	X	

Note

- O: Possible, X: Impossible, -: Not applicable, Embedded: Included with product.
- Some advanced functions controlled by individual controller cannot be operated.
- If there is a difference in development time between the product and the remote controller, some functions cannot be operated.
- Meter interface cannot be connected at the same time with 3rd-party controller.
- *: It includes double-sensor for solar tank. The collector sensor (PT1000) needs to be supplied locally.
- If you need more detail, please refer to the control(**BECOM**) PDB or the manual of product. (<http://partner.lge.com> > Select Your Region : Home> Doc.Library> Product > Control(BECON)).

1. List of Functions

Category	Product	Remark	ZHBW056A2 [HM051MRS UA40] ZHBW076A2 [HM071MRS UA40] ZHBW096A2 [HM091MRS UA40] ZHBW126A2 [HM121MRS UB40] ZHBW146A2 [HM141MRS UB40] ZHBW166A2 [HM161MRS UB40] ZHBW128A2 [HM123MRS UB40] ZHBW148A2 [HM143MRS UB40] ZHBW168A2 [HM163MRS UB40]	
Central Controller	AC EZ	PQCSZ250S0	AC EZ	X
	AC Ez Touch	PACEZA000	AC Ez Touch	O
	AC Smart	PACS5A000	AC Smart 5	O
	ACP	PACP5A000	ACP 5	O
	AC Manager **	PACM5A000	AC Manager 5	X
Gateway	IDU PI485	PHNFP14A0	Without case	X
		PSNFP14A0	With case	X
	ODU PI485	PP485A00T	PI 485 Gateway	X
		PMNFP14A1	PI 485 Gateway (Produced before 1st of Sep. of 2021)	X
	BACnet	PQNFB17C0	ACP BACnet	X
	Lonworks	PLNWKB000	ACP Lonworks	X
	Modbus	PMBUSB00A	-	O
Cloud Gateway	PWFMDB200	Cloud (ThinQ, BECON)	O	
ETC	PDI	PPWRDB000	PDI Standard	X
		PQNUD1S40	PDI Premium	X
	ACS IO Module	PEXPMB000	-	X

Note

1. O: Possible, X: Impossible, - : Not applicable
2. **: ACP or AC Smart is needed.
3. If you need more detail, please refer to the manual of product.
(<http://partner.lge.com> > Select Your Region : Home> Doc.Library> Product > Control(BECON))

2. Specification

■ 1 phase Inverter (5.5 ~ 9 kW)

Nominal Capacity and Nominal Input					ZHBW056A2 [HM051MRS UA40]	ZHBW076A2 [HM071MRS UA40]	ZHBW096A2 [HM091MRS UA40]
-	-	Outdoor Temp. (°C) DB / WB	Leaving Water Temp. (°C)	-			
Capacity	Cooling	35 / 24	18	kW	5.50	7.00	9.00
			7	kW	5.50	7.00	9.00
	Heating	7 / 6	35	kW	5.50	7.00	9.00
			55	kW	5.50	5.75	6.00
		2 / 1	35	kW	5.00	6.00	7.00
Power Input	Cooling	35 / 24	18	kW	1.17	1.51	1.96
			7	kW	1.67	2.19	3.00
	Heating	7 / 6	35	kW	1.17	1.49	1.96
			55	kW	2.04	2.13	2.22
		2 / 1	35	kW	1.39	1.69	2.00
EER	Cooling	35 / 24	18	W/W	4.70	4.65	4.60
			7	W/W	3.30	3.20	3.00
COP	Heating	7 / 6	35	W/W	4.70	4.70	4.60
			55	W/W	2.70	2.70	2.70
		2 / 1	35	W/W	3.60	3.55	3.50
SCOP (Low temp. Average Climate)*					4.46	4.48	4.55
SCOP (Medium temp. Average Climate)*					3.20	3.20	3.20
Rated Water Flow Rate (at LWT 35 °C)				LPM	15.8	20.1	25.9

Electrical Specifications				ZHBW056A2 [HM051MRS UA40]	ZHBW076A2 [HM071MRS UA40]	ZHBW096A2 [HM091MRS UA40]	
Power Supply			V, Ø, Hz	220-240, 1, 50	220-240, 1, 50	220-240, 1, 50	
Peak Control Running Current			A	13.0	14.0	15.0	
Rated Running Current	Cooling			A	5.1	6.5	8.5
	Heating			A	5.1	6.5	8.5
Circuit breaker			A	16	20	25	
Wiring Connections	Power Supply Cable (included Earth, H07RN-F)		mm ² x cores	4.0 x 3C	4.0 x 3C	4.0 x 3C	

Technical Specifications				ZHBW056A2 [HM051MRS UA40]	ZHBW076A2 [HM071MRS UA40]	ZHBW096A2 [HM091MRS UA40]
Sound Power Level	Heating	Day Max.	dB(A)	63	64	64
		Rated	dB(A)	57	57	57
		Low noise	dB(A)	54	55	55
Dimensions	Unit	W x H x D	mm	1,242 x 853 x 391	1,242 x 853 x 391	1,242 x 853 x 391
	Packed Unit	W x H x D	mm	1,330 x 1017 x 480	1,330 x 1017 x 480	1,330 x 1017 x 480
Weight	Unit		kg	94	94	94
	Packed Unit		kg	108	108	108
Exterior	Color		-	Black STS Silver Solid	Black STS Silver Solid	Black STS Silver Solid
	RAL Code		-	-	-	-
	Color of Front Grille		-	Light Graphite	Light Graphite	Light Graphite
	RAL Code of Front Grille		-	-	-	-

Note

- Due to our policy of innovation, some specifications may be changed without notification.
- Wiring cable size must comply with the applicable local and national codes. And "Electric characteristics" chapter should be considered for electrical work and design. Especially the power cable and circuit breaker should be selected in accordance with that.
- Sound power level is measured in accordance with EN 12102-1 and ISO 9614.
 - Rated : This mode is measured on the rated condition in the semi-anechoic rooms. Therefore, these values may vary depending on operation conditions.
 - Daytime max : This mode is measured based on max. fan RPM and max. compressor Hz. that can be reached under outdoor air temperature 2°C.
 - Low noise : This mode lowers noise by limiting the compressor Hz. and fan RPM, and thus the performance may be limited.
- Performances are accordance with EN14511 and reflect ErP testing conditions. The values indicated above are the declared values at rated conditions acc. ErP regulation. For max. capacities, please refer to Performance Data.
- This product contains Fluorinated greenhouse gases.
- SCOP is in accordance with EN14825.
- Rated running currents are based on the declared values under the following conditions.
 - Heating : Outdoor Temp. 7°CDB / 6°CWB, Leaving Water Temp. 35°C
 - Cooling : Outdoor Temp. 35°C(DB) / 24°C(WB), Leaving Water Temp. 18°C
- All installation sites must be equipped with an earth leakage circuit breaker (ELCB).
 - * DHW 55~80°C Operating is available only when the booster heater is operating.
 - ** This is the power input in accordance with the 80% pump capacity setting at rated water flow rate. When the OH SUNG pump is set as 80% capacity, it's head is similar to that of the GRUNDFOS pump at rated water flow rate.

2. Specification

Technical Specifications (Water side)				ZHBW056A2 [HM051MRS UA40]	ZHBW076A2 [HM071MRS UA40]	ZHBW096A2 [HM091MRS UA40]
Operation Range (Leaving Water Temp.)	Cooling	Min. ~ Max.	°C	5 ~ 27	5 ~ 27	5 ~ 27
	Heating	Min. ~ Max.	°C	15 ~ 65	15 ~ 65	15 ~ 65
	DHW *	Min. ~ Max.	°C	15 ~ 80	15 ~ 80	15 ~ 80
Water Pump***	Type	Canned type for hot water circulation				
	Model	UPM3K 20-75 CHBL / GRUNDFOS				
	Model Type	BLDC				
	Steps of Pumping Performance	Variable speed 10% to 100%				
	Power input (100% Capacity)	Min. / Rated	W	3 / 57	3 / 60	3 / 60
	Water Flow Rate	Min. / Rated	ℓ/min	0 / 15.8	0 / 20.1	0 / 25.9
Water Pump_2***	Type	Canned type for hot water circulation				
	Model	ODM-061P / OH SUNG				
	Motor Type	BLDC				
	Steps of Pumping Performance	Variable speed 10% to 100%				
	Power input (100% Capacity)	Min. / Rated	W	17 / 91.0 (55**)	17 / 98.0 (60**)	17 / 110.0 (65**)
	Water Flow Rate	Min. / Rated	ℓ/min	0 / 15.8	0 / 20.1	0 / 25.9
Heat Exchanger	Type	Brazed Plate HEX				
	Quantity	1				
	Number of Plate	EA 52				
	Water Volume	ℓ 0.7				
Expansion Vessel	Volume	Max.	ℓ	8	8	8
	Water pressure	Max.	bar	3.2	3.2	3.2
		Pre-charged	bar	1	1	1
Flow Sensor****	Model	SIKA VVX20				
	Measuring range	Min. ~ Max.	ℓ/min	5~80	5~80	5~80
	Flow (Trigger point)	Min.	ℓ/min	5	5	5
Flow Sensor_2****	Model	SEBA LGF-080-C20-E-C0.5V				
	Measuring range	Min. ~ Max.	ℓ/min	5~80	5~80	5~80
	Flow (Trigger point)	Min.	ℓ/min	5	5	5
Water Pressure sensor	Model	Sensata OFM(2HMP)				
	Measuring range	Min. ~ Max.	bar(G)	0 ~ 20	0 ~ 20	0 ~ 20
Piping Connections	Inlet	inch Male PT 1" according to ISO 7-1 (tapered pipe threads)				
	Outlet	inch Male PT 1" according to ISO 7-1 (tapered pipe threads)				
Water strainer	Supply type	Loose supply(externally installed)				
	Mesh size	30 mesh				
	Max. particle size	mm 0.6				
	Material	Stainless Steel				
Relief Valve	Pressure Limit	Upper Limit	bar	3.0	3.0	3.0
	Devices for Water Circuit			-	Relief valve / Flow Sensor	
			-	Drain hose		
			-	Pressure Sensor / Air vent		

Note

- Due to our policy of innovation, some specifications may be changed without notification.
- Wiring cable size must comply with the applicable local and national codes. And "Electric characteristics" chapter should be considered for electrical work and design. Especially the power cable and circuit breaker should be selected in accordance with that.
- Sound power level is measured in accordance with EN 12102-1 and ISO 9614.
 - Rated : This mode is measured on the rated condition in the semi-anechoic rooms. Therefore, these values may vary depending on operation conditions.
 - Daytime max : This mode is measured based on max. fan RPM and max. compressor Hz. that can be reached under outdoor air temperature 2°C.
 - Low noise : This mode lowers noise by limiting the compressor Hz. and fan RPM, and thus the performance may be limited.
- Performances are accordance with EN14511 and reflect ErP testing conditions. The values indicated above are the declared values at rated conditions acc. ErP regulation. For max. capacities, please refer to Performance Data.
- This product contains Fluorinated greenhouse gases.
- SCOP is in accordance with EN14825.
- Rated running currents are based on the declared values under the following conditions.
 - Heating : Outdoor Temp. 7°CDB / 6°CWB, Leaving Water Temp. 35°C
 - Cooling : Outdoor Temp. 35°C(DB) / 24°C(WB), Leaving Water Temp. 18°C
- All installation sites must be equipped with an earth leakage circuit breaker (ELCB).
 - * DHW 55~80°C Operating is available only when the booster heater is operating.
 - ** This is the power input i accordance with the 80% pump capacity setting at rated water flow rate. When the OH SUNG pump is set as 80% capacity, it's head is similar to that of the GRUNDFOS pump at rated water flow rate.
 - *** In the case of integrated water pump, either water pump or water pump 2 will be applied.
 - **** In the case of integrated flow sensor, either flow sensor or flow sensor 2 will be applied.

2. Specification

Technical Specifications (Refrigerant side)				ZHBW056A2 [HM051MRS UA40]	ZHBW076A2 [HM071MRS UA40]	ZHBW096A2 [HM091MRS UA40]
Operation Range (Outdoor Temp.)	Cooling#	Min. ~ Max.	°C DB	5 ~ 48	5 ~ 48	5 ~ 48
	Heating	Min. ~ Max.	°C DB	-25 ~ 35	-25 ~ 35	-25 ~ 35
Compressor	Type	Hermetic Sealed Scroll				
	Model	Model × No.	RJB036MAA × 1			
	Motor Type	BLDC				
	Displacement	cm ³ /Rev.	31.6	31.6	31.6	
Refrigerant	Type	R32				
	GWP (Global Warming Potential)	-	675.0	675.0	675.0	
	Precharged Amount	g	1,400	1,400	1,400	
	t-CO2 eq.	-	0.945	0.945	0.945	
	Control	Electronic Expansion Valve				
Refrigerant Oil	Type	FW68D				
	Charged Volume	cc × No.	1,100	1,100	1,100	
Heat Exchanger	Type	Fin & Tube				
	Quantity	1				
	Specification	Row	EA	38	38	38
		Column	EA	2	2	2
FPI		EA	18	18	18	
Fan	Type	Propeller				
	Air Flow Rate	Rated	m ³ /min × No.	60.0 × 1	60.0 × 1	60.0 × 1
Fan Motor	Type	BLDC				
	Output	W × No.	124 × 1	124 × 1	124 × 1	

Note

- Due to our policy of innovation, some specifications may be changed without notification.
 - Wiring cable size must comply with the applicable local and national codes. And "Electric characteristics" chapter should be considered for electrical work and design. Especially the power cable and circuit breaker should be selected in accordance with that.
 - Sound power level is measured in accordance with EN 12102-1 and ISO 9614.
 - Rated : This mode is measured on the rated condition in the semi-anechoic rooms. Therefore, these values may vary depending on operation conditions.
 - Daytime max : This mode is measured based on max. fan RPM and max. compressor Hz. that can be reached under outdoor air temperature 2°C.
 - Low noise : This mode lowers noise by limiting the compressor Hz. and fan RPM, and thus the performance may be limited.
 - Performances are accordance with EN14511 and reflect ErP testing conditions. The values indicated above are the declared values at rated conditions acc. ErP regulation. For max. capacities, please refer to Performance Data.
 - This product contains Fluorinated greenhouse gases.
 - SCOP is in accordance with EN14825.
 - Rated running currents are based on the declared values under the following conditions.
 - Heating : Outdoor Temp. 7°CDB / 6°CWB, Leaving Water Temp. 35°C
 - Cooling : Outdoor Temp. 35°C(DB) / 24°C(WB), Leaving Water Temp. 18°C
 - All installation sites must be equipped with an earth leakage circuit breaker (ELCB).
 - * DHW 55~80°C Operating is available only when the booster heater is operating.
 - ** This is the power input in accordance with the 80% pump capacity setting at rated water flow rate. When the OH SUNG pump is set as 80% capacity, it's head is similar to that of the GRUNDFOS pump at rated water flow rate.
- # This operation range includes not only the continuous operation range but also operative range.

2. Specification

■ 1 phase Inverter (12 ~ 16 kW)

Nominal Capacity and Nominal Input					ZHBW126A2 [HM121MRS UB40]	ZHBW146A2 [HM141MRS UB40]	ZHBW166A2 [HM161MRS UB40]
-	-	Outdoor Temp. (°C) DB / WB	Leaving Water Temp. (°C)	-			
Capacity	Cooling	35 / 24	18	kW	12.00	14.00	16.00
			7	kW	12.00	14.00	15.00
	Heating	7 / 6	35	kW	12.00	14.00	16.00
			55	kW	11.00	11.50	12.00
		2 / 1	35	kW	11.00	12.00	13.80
Power Input	Cooling	35 / 24	18	kW	2.50	2.98	3.48
			7	kW	3.75	4.52	5.00
	Heating	7 / 6	35	kW	2.45	2.92	3.40
			55	kW	3.79	4.04	4.29
		2 / 1	35	kW	3.06	3.38	3.94
EER	Cooling	35 / 24	18	W/W	4.80	4.70	4.60
			7	W/W	3.20	3.10	3.00
COP	Heating	7 / 6	35	W/W	4.90	4.80	4.70
			55	W/W	2.90	2.85	2.80
		2 / 1	35	W/W	3.60	3.55	3.50
SCOP (Low temp. Average Climate)*					4.67	4.62	4.53
SCOP ((Medium temp. Average Climate)*					3.47	3.46	3.45
Rated Water Flow Rate (at LWT 35 °C)				LPM	34.5	40.3	46.0

Electrical Specifications			ZHBW126A2 [HM121MRS UB40]	ZHBW146A2 [HM141MRS UB40]	ZHBW166A2 [HM161MRS UB40]
Power Supply		V, Ø, Hz	220-240, 1, 50	220-240, 1, 50	220-240, 1, 50
Peak Control Running Current		A	23.0	24.0	25.0
Rated Running Current	Cooling	A	10.6	12.7	14.8
	Heating	A	10.9	13.0	15.1
Circuit breaker		A	40	40	40
Wiring Connections	Power Supply Cable (included Earth, H07RN-F)	mm ² x cores	6.0 x 3C	6.0 x 3C	6.0 x 3C

Technical Specifications				ZHBW126A2 [HM121MRS UB40]	ZHBW146A2 [HM141MRS UB40]	ZHBW166A2 [HM161MRS UB40]
Sound Power Level	Heating	Day Max.	dB(A)	65	66	66
		Rated	dB(A)	60	61	61
		Low noise	dB(A)	56	57	57
Dimensions	Unit	W x H x D	mm	1,320 x 1,019 x 520	1,320 x 1,019 x 520	1,320 x 1,019 x 520
	Packed Unit	W x H x D	mm	1,380 x 1,200 x 575	1,380 x 1,200 x 575	1,380 x 1,200 x 575
Weight	Unit		kg	117.0	117.0	117.0
	Packed Unit		kg	134.0	134.0	134.0
Exterior	Color		-	Black STS Silver Solid	Black STS Silver Solid	Black STS Silver Solid
	RAL Code		-	-	-	-
	Color of Front Grille		-	Light Graphite	Light Graphite	Light Graphite
	RAL Code of Front Grille		-	-	-	-

Note

- Due to our policy of innovation, some specifications may be changed without notification.
- Wiring cable size must comply with the applicable local and national codes. And "Electric characteristics" chapter should be considered for electrical work and design. Especially the power cable and circuit breaker should be selected in accordance with that.
- Sound power level is measured in accordance with EN 12102-1 and ISO 9614.
 - Rated : This mode is measured on the rated condition in the semi-anechoic rooms. Therefore, these values may vary depending on operation conditions.
 - Daytime max : This mode is measured based on max. fan RPM and max. compressor Hz. that can be reached under outdoor air temperature 2°C.
 - Low noise : This mode lowers noise by limiting the compressor Hz. and fan RPM, and thus the performance may be limited.
- Performances are accordance with EN14511 and reflect ErP testing conditions. The values indicated above are the declared values at rated conditions acc. ErP regulation. For max. capacities, please refer to Performance Data.
- This product contains Fluorinated greenhouse gases.
- SCOP is in accordance with EN14825.
- Rated running currents are based on the declared values under the following conditions.
 - Heating : Outdoor Temp. 7°CDB / 6°CWB, Leaving Water Temp. 35 °C
 - Cooling : Outdoor Temp. 35°C(DB) / 24°C(WB), Leaving Water Temp. 18°C
- All installation sites must be equipped with an earth leakage circuit breaker (ELCB).
 - * DHW 55~80°C Operating is available only when the booster heater is operating.

** This is the power input i accordance with the 80% pump capacity setting at rated water flow rate. When the OH SUNG pump is set as 80% capacity, it's head is similar to that of the GRUNDFOS pump at rated water flow rate.



2. Specification

Technical Specifications (Water side)				ZHBW126A2 [HM121MRS UB40]	ZHBW146A2 [HM141MRS UB40]	ZHBW166A2 [HM161MRS UB40]
Operation Range (Leaving Water Temp.)	Cooling	Min. ~ Max.	°C	5 ~ 27	5 ~ 27	5 ~ 27
	Heating	Min. ~ Max.	°C	15 ~ 65	15 ~ 65	15 ~ 65
	DHW *	Min. ~ Max.	°C	15 ~ 80	15 ~ 80	15 ~ 80
Water Pump***	Type	Canned type for hot water circulation				
	Model	UPML 20-105 CHBL / GRUNDFOS				
	Motor Type	BLDC				
	Steps of Pumping Performance	Variable speed 10% to 100%				
	Power input (100% Capacity)	Min. / Rated	W	3.5 / 125	3.5 / 135	3.5 / 140
	Water Flow Rate	Min. / Rated	ℓ/min	0 / 34.5	0 / 40.3	0 / 46.0
Water Pump_2***	Type	Canned type for hot water circulation				
	Model	ODM-061P / OH SUNG				
	Motor Type	BLDC				
	Steps of Pumping Performance	Variable speed 10% to 100%				
	Power input (100% Capacity)	Min. / Rated	W	17 / 130	17 / 140	17 / 145
	Water Flow Rate	Min. / Rated	ℓ/min	0 / 34.5	0 / 40.3	0 / 46.0
Heat Exchanger	Type	Brazed Plate HEX				
	Quantity	1				
	Number of Plate	EA 76				
	Water Volume	ℓ 1.0				
Expansion Vessel	Volume	Max.	ℓ	8	8	8
	Water pressure	Max.	bar	3.2	3.2	3.2
		Pre-charged	bar	1	1	1
Flow Sensor****	Model	SIKA VVX20				
	Measuring range	Min. ~ Max.	ℓ/min	5~80	5~80	5~80
	Flow (Trigger point)	Min.	ℓ/min	10	10	10
Flow Sensor_2****	Model	SEBA LGF-080-C20-E-C0.5V				
	Measuring range	Min. ~ Max.	ℓ/min	5~80	5~80	5~80
	Flow (Trigger point)	Min.	ℓ/min	5	5	5
Water Pressure sensor	Model	Sensata OFM(2HMP)				
	Measuring range	Min. ~ Max.	bar(G)	0 ~ 20	0 ~ 20	0 ~ 20
Piping Connections	Inlet	inch Male PT 1" according to ISO 7-1 (tapered pipe threads)				
	Outlet	inch Male PT 1" according to ISO 7-1 (tapered pipe threads)				
Water strainer	Supply type	Loose supply(externally installed)				
	Mesh size	30 mesh				
	Max. particle size	mm 0.6				
	Material	Stainless Steel				
Relief Valve	Pressure Limit	Upper Limit	bar	3.0	3.0	3.0
	Devices for Water Circuit			-	Relief valve / Flow Sensor	
			-	Drain hose		
			-	Pressure Sensor / Air vent		

Note

- Due to our policy of innovation, some specifications may be changed without notification.
- Wiring cable size must comply with the applicable local and national codes. And "Electric characteristics" chapter should be considered for electrical work and design. Especially the power cable and circuit breaker should be selected in accordance with that.
- Sound power level is measured in accordance with EN 12102-1 and ISO 9614.
 - Rated : This mode is measured on the rated condition in the semi-anechoic rooms. Therefore, these values may vary depending on operation conditions.
 - Daytime max : This mode is measured based on max. fan RPM and max. compressor Hz. that can be reached under outdoor air temperature 2°C.
 - Low noise : This mode lowers noise by limiting the compressor Hz. and fan RPM, and thus the performance may be limited.
- Performances are accordance with EN14511 and reflect ErP testing conditions. The values indicated above are the declared values at rated conditions acc. ErP regulation. For max. capacities, please refer to Performance Data.
- This product contains Fluorinated greenhouse gases.
- SCOP is in accordance with EN14825.
- Rated running currents are based on the declared values under the following conditions.
 - Heating : Outdoor Temp. 7°CDB / 6°CWB, Leaving Water Temp. 35°C
 - Cooling : Outdoor Temp. 35°C(DB) / 24°C(WB), Leaving Water Temp. 18°C
- All installation sites must be equipped with an earth leakage circuit breaker (ELCB).
 - * DHW 55~80°C Operating is available only when the booster heater is operating.
 - ** This is the power input i accordance with the 80% pump capacity setting at rated water flow rate. When the OH SUNG pump is set as 80% capacity, it's head is similar to that of the GRUNDFOS pump at rated water flow rate.
 - *** In the case of integrated water pump, either water pump or water pump 2 will be applied.
 - **** In the case of integrated flow sensor, either flow sensor or flow sensor 2 will be applied.

2. Specification

Technical Specifications (Refrigerant side)				ZHBW126A2 [HM121MRS UB40]	ZHBW146A2 [HM141MRS UB40]	ZHBW166A2 [HM161MRS UB40]
Operation Range (Outdoor Temp.)	Cooling#	Min. ~ Max.	°C DB	5 ~ 48	5 ~ 48	5 ~ 48
	Heating	Min. ~ Max.	°C DB	-25 ~ 35	-25 ~ 35	-25 ~ 35
Compressor	Type	Hermetic Sealed Scroll				
	Model	Model × No.	RJB036MAA × 1			
	Motor Type	BLDC				
	Displacement	cm ³ /Rev.	31.6	31.6	31.6	
Refrigerant	Type	R32				
	GWP (Global Warming Potential)	-	675.0	675.0	675.0	
	Precharged Amount	g	1,600	1,600	1,600	
	t-CO2 eq.	-	1,080	1,080	1,080	
	Control	Electronic Expansion Valve				
Refrigerant Oil	Type	FW68D				
	Charged Volume	cc × No.	1,100	1,100	1,100	
Heat Exchanger	Type	Fin & Tube				
	Quantity	1				
	Specification	Row	EA	46	46	46
		Column	EA	2	2	2
FPI		EA	18	18	18	
Fan	Type	Propeller				
	Air Flow Rate	Rated	m ³ /min × No.	100.0 x 1	100.0 x 1	100.0 x 1
Fan Motor	Type	BLDC				
	Output	W × No.	250 x 1	250 x 1	250 x 1	

Note

- Due to our policy of innovation, some specifications may be changed without notification.
 - Wiring cable size must comply with the applicable local and national codes. And "Electric characteristics" chapter should be considered for electrical work and design. Especially the power cable and circuit breaker should be selected in accordance with that.
 - Sound power level is measured in accordance with EN 12102-1 and ISO 9614.
 - Rated : This mode is measured on the rated condition in the semi-anechoic rooms. Therefore, these values may vary depending on operation conditions.
 - Daytime max : This mode is measured based on max. fan RPM and max. compressor Hz. that can be reached under outdoor air temperature 2°C.
 - Low noise : This mode lowers noise by limiting the compressor Hz. and fan RPM, and thus the performance may be limited.
 - Performances are accordance with EN14511 and reflect ErP testing conditions. The values indicated above are the declared values at rated conditions acc. ErP regulation. For max. capacities, please refer to Performance Data.
 - This product contains Fluorinated greenhouse gases.
 - SCOP is in accordance with EN14825.
 - Rated running currents are based on the declared values under the following conditions.
 - Heating : Outdoor Temp. 7°CDB / 6°CWB, Leaving Water Temp. 35°C
 - Cooling : Outdoor Temp. 35°C(DB) / 24°C(WB), Leaving Water Temp. 18°C
 - All installation sites must be equipped with an earth leakage circuit breaker (ELCB).
 - * DHW 55~80°C Operating is available only when the booster heater is operating.
 - ** This is the power input in accordance with the 80% pump capacity setting at rated water flow rate. When the OH SUNG pump is set as 80% capacity, it's head is similar to that of the GRUNDFOS pump at rated water flow rate.
- # This operation range includes not only the continuous operation range but also operative range.

2. Specification

■ 3 phase Inverter (12 ~ 16 kW)

Nominal Capacity and Nominal Input					ZHBW128A2 [HM123MRS UB40]	ZHBW148A2 [HM143MRS UB40]	ZHBW168A2 [HM163MRS UB40]
-	-	Outdoor Temp (°C) DB / WB	Leaving Water Temp (°C)	-			
Capacity	Cooling	35 / 24	18	kW	12.00	14.00	16.00
			7	kW	12.00	14.00	15.00
	Heating	7 / 6	35	kW	12.00	14.00	16.00
			55	kW	11.00	11.50	12.00
		2 / 1	35	kW	11.00	12.00	13.80
Power Input	Cooling	35 / 24	18	kW	2.50	2.98	3.48
			7	kW	3.75	4.52	5.00
	Heating	7 / 6	35	kW	2.45	2.92	3.40
			55	kW	3.79	4.04	4.29
		2 / 1	35	kW	3.06	3.38	3.94
EER	Cooling	35 / 24	18	W/W	4.80	4.70	4.60
			7	W/W	3.20	3.10	3.00
COP	Heating	7 / 6	35	W/W	4.90	4.80	4.70
			55	W/W	2.90	2.85	2.80
		2 / 1	35	W/W	3.60	3.55	3.50
SCOP (Low temp. Average Climate)*					4.67	4.62	4.53
SCOP ((Medium temp. Average Climate)*					3.47	3.46	3.45
Rated Water Flow Rate (at LWT 35 °C)				LPM	34.5	40.3	46.0

Electrical Specifications				ZHBW128A2 [HM123MRS UB40]	ZHBW148A2 [HM143MRS UB40]	ZHBW168A2 [HM163MRS UB40]
Power Supply		V, Ø, Hz		380-415, 3, 50	380-415, 3, 50	380-415, 3, 50
Peak Control Running Current		A		8.0	9.0	10.0
Rated Running Current	Cooling	A		3.5	4.2	4.9
	Heating	A		3.6	4.3	5.0
Circuit breaker		A		16	16	16
Wiring Connections	Power Supply Cable (included Earth, H07RN-F)	mm ² x cores		4.0 x 5C	4.0 x 5C	4.0 x 5C

Technical Specifications				ZHBW128A2 [HM123MRS UB40]	ZHBW148A2 [HM143MRS UB40]	ZHBW168A2 [HM163MRS UB40]
Sound Power Level	Heating	Day Max.	dB(A)	65	66	66
		Rated	dB(A)	60	61	61
		Low noise	dB(A)	56	57	57
Dimensions	Unit	W x H x D	mm	1,320 x 1,019 x 520	1,320 x 1,019 x 520	1,320 x 1,019 x 520
	Packed Unit	W x H x D	mm	1,380 x 1,200 x 575	1,380 x 1,200 x 575	1,380 x 1,200 x 575
Weight	Unit			kg	117.0	117.0
	Packed Unit			kg	134.0	134.0
Exterior	Color			-	Black STS Silver Solid	Black STS Silver Solid
	RAL Code			-	-	-
	Color of Front Grille			-	Light Graphite	Light Graphite
	RAL Code of Front Grille			-	-	-

Note

- Due to our policy of innovation, some specifications may be changed without notification.
- Wiring cable size must comply with the applicable local and national codes. And "Electric characteristics" chapter should be considered for electrical work and design. Especially the power cable and circuit breaker should be selected in accordance with that.
- Sound power level is measured in accordance with EN 12102-1 and ISO 9614.
 - Rated : This mode is measured on the rated condition in the semi-anechoic rooms. Therefore, these values may vary depending on operation conditions.
 - Daytime max : This mode is measured based on max. fan RPM and max. compressor Hz. that can be reached under outdoor air temperature 2°C.
 - Low noise : This mode lowers noise by limiting the compressor Hz. and fan RPM, and thus the performance may be limited.
- Performances are accordance with EN14511 and reflect ErP testing conditions. The values indicated above are the declared values at rated conditions acc. ErP regulation. For max. capacities, please refer to Performance Data.
- This product contains Fluorinated greenhouse gases.
- SCOP is in accordance with EN14825.
- Rated running currents are based on the declared values under the following conditions.
 - Heating : Outdoor Temp. 7°CDB / 6°CWB, Leaving Water Temp. 35°C
 - Cooling : Outdoor Temp. 35°C(DB) / 24°C(WB), Leaving Water Temp. 18°C
- All installation sites must be equipped with an earth leakage circuit breaker (ELCB).
 - * DHW 55~80°C Operating is available only when the booster heater is operating.
 - ** This is the power input i accordance with the 80% pump capacity setting at rated water flow rate. When the OH SUNG pump is set as 80% capacity, it's head is similar to that of the GRUNDFOS pump at rated water flow rate.

2. Specification

Technical Specifications (Water side)				ZHBW128A2 [HM123MRS UB40]	ZHBW148A2 [HM143MRS UB40]	ZHBW168A2 [HM163MRS UB40]
Operation Range (Leaving Water Temp.)	Cooling	Min. ~ Max.	°C	5 ~ 27	5 ~ 27	5 ~ 27
	Heating	Min. ~ Max.	°C	15 ~ 65	15 ~ 65	15 ~ 65
	DHW *	Min. ~ Max.	°C	15 ~ 80	15 ~ 80	15 ~ 80
Water Pump***	Type		-	Canned type for hot water circulation		
	Model		-	UPML 20-105 CHBL / GRUNDFOS		
	Motor Type		-	BLDC		
	Steps of Pumping Performance		-	Variable speed 10% to 100%		
	Power input (100% Capacity)	Min. / Rated	W	3.5 / 125	3.5 / 135	3.5 / 140
	Water Flow Rate	Min. / Rated	ℓ/min	0 / 34.5	0 / 40.3	0 / 46.0
Water Pump_2***	Type		-	Canned type for hot water circulation		
	Model		-	ODM-061P / OH SUNG		
	Motor Type		-	BLDC		
	Steps of Pumping Performance		-	Variable speed 10% to 100%		
	Power input (100% Capacity)	Min. / Rated	W	17 / 130	17 / 140	17 / 145
	Water Flow Rate	Min. / Rated	ℓ/min	0 / 34.5	0 / 40.3	0 / 46.0
Heat Exchanger	Type		-	Braze Plate HEX		
	Quantity		-	1	1	1
	Number of Plate		EA	76	76	76
	Water Volume		ℓ	1.0	1.0	1.0
Expansion Vessel	Volume	Max.	ℓ	8	8	8
	Water pressure	Max.	bar	3.2	3.2	3.2
		Pre-charged	bar	1	1	1
Flow Sensor****	Model		-	SIKA VVX20		
	Measuring range	Min. ~ Max.	ℓ/min	5 ~ 80	5~80	5~80
	Flow (Trigger point)	Min.	ℓ/min	10	10	10
Flow Sensor_2****	Model		-	SEBA LGF-080-C20-E-C0.5V		
	Measuring range	Min. ~ Max.	ℓ/min	5~80	5~80	5~80
	Flow (Trigger point)	Min.	ℓ/min	10	10	10
Water Pressure sensor	Model		-	Sensata OFM(2HMP)		
	Measuring range	Min. ~ Max.	bar(G)	0 ~ 20	0~20	0~20
Piping Connections	Inlet		inch	Male PT 1" according to ISO 7-1 (tapered pipe threads)		
	Outlet		inch	Male PT 1" according to ISO 7-1 (tapered pipe threads)		
Water strainer	Supply type		-	Loose supply(externally installed)		
	Mesh size		-	30 mesh	30 mesh	30 mesh
	Max. particle size		mm	0.6	0.6	0.6
	Material		-	Stainless Steel	Stainless Steel	Stainless Steel
Relief Valve	Pressure Limit	Upper Limit	bar	3.0	3.0	3.0
Devices for Water Circuit			-	Relief valve / Flow Sensor		
			-	Drain hose		
			-	Pressure Sensor / Air vent		

Note

- Due to our policy of innovation, some specifications may be changed without notification.
- Wiring cable size must comply with the applicable local and national codes. And "Electric characteristics" chapter should be considered for electrical work and design. Especially the power cable and circuit breaker should be selected in accordance with that.
- Sound power level is measured in accordance with EN 12102-1 and ISO 9614.
 - Rated : This mode is measured on the rated condition in the semi-anechoic rooms. Therefore, these values may vary depending on operation conditions.
 - Daytime max : This mode is measured based on max. fan RPM and max. compressor Hz. that can be reached under outdoor air temperature 2°C.
 - Low noise : This mode lowers noise by limiting the compressor Hz. and fan RPM, and thus the performance may be limited.
- Performances are accordance with EN14511 and reflect ErP testing conditions. The values indicated above are the declared values at rated conditions acc. ErP regulation. For max. capacities, please refer to Performance Data.
- This product contains Fluorinated greenhouse gases.
- SCOP is in accordance with EN14825.
- Rated running currents are based on the declared values under the following conditions.
 - Heating : Outdoor Temp. 7°CDB / 6°CWB, Leaving Water Temp. 35°C
 - Cooling : Outdoor Temp. 35°C(DB) / 24°C(WB), Leaving Water Temp. 18°C
- All installation sites must be equipped with an earth leakage circuit breaker (ELCB).
 - * DHW 55~80°C Operating is available only when the booster heater is operating.
 - ** This is the power input i accordance with the 80% pump capacity setting at rated water flow rate. When the OH SUNG pump is set as 80% capacity, it's head is similar to that of the GRUNDFOS pump at rated water flow rate.
 - *** In the case of integrated water pump, either water pump or water pump 2 will be applied.
 - **** In the case of integrated flow sensor, either flow sensor or flow sensor 2 will be applied.

2. Specification

Technical Specifications (Refrigerant side)				ZHBW128A2 [HM123MRS UB40]	ZHBW148A2 [HM143MRS UB40]	ZHBW168A2 [HM163MRS UB40]	
Operation Range (Outdoor Temp.)	Cooling#	Min. ~ Max.	°C DB	5 ~ 48	5 ~ 48	5 ~ 48	
	Heating	Min. ~ Max.	°C DB	-25 ~ 35	-25 ~ 35	-25 ~ 35	
Compressor	Type			Hermetic Sealed Scroll			
	Model	Model × No.		RJB036MAA × 1			
	Motor Type			BLDC	BLDC	BLDC	
	Displacement	cm ³ /Rev.		31.6	31.6	31.6	
Refrigerant	Type			R32	R32	R32	
	GWP (Global Warming Potential)			675.0	675.0	675.0	
	Precharged Amount	g		1,600	1,600	1,600	
	t-CO2 eq.			1,080	1,080	1,080	
	Control			Electronic Expansion Valve			
Refrigerant Oil	Type			FW68D	FW68D	FW68D	
	Charged Volume	cc × No.		1,100	1,100	1,100	
Heat Exchanger	Type			Fin & Tube	Fin & Tube	Fin & Tube	
	Quantity			1	1	1	
	Specification	Row	EA		46	46	46
		Column	EA		2	2	2
FPI		EA		18	18	18	
Fan	Type			Propeller	Propeller	Propeller	
	Air Flow Rate	Rated	m ³ /min × No.	100.0 x 1	100.0 x 1	100.0 x 1	
Fan Motor	Type			BLDC	BLDC	BLDC	
	Output	W × No.		250 x 1	250 x 1	250 x 1	

Note

- Due to our policy of innovation, some specifications may be changed without notification.
- Wiring cable size must comply with the applicable local and national codes. And "Electric characteristics" chapter should be considered for electrical work and design. Especially the power cable and circuit breaker should be selected in accordance with that.
- Sound power level is measured in accordance with EN 12102-1 and ISO 9614.
 - Rated : This mode is measured on the rated condition in the semi-anechoic rooms. Therefore, these values may vary depending on operation conditions.
 - Daytime max : This mode is measured based on max. fan RPM and max. compressor Hz. that can be reached under outdoor air temperature 2°C.
 - Low noise : This mode lowers noise by limiting the compressor Hz. and fan RPM, and thus the performance may be limited.
- Performances are accordance with EN14511 and reflect ErP testing conditions. The values indicated above are the declared values at rated conditions acc. ErP regulation. For max. capacities, please refer to Performance Data.
- This product contains Fluorinated greenhouse gases.
- SCOP is in accordance with EN14825.
- Rated running currents are based on the declared values under the following conditions.
 - Heating : Outdoor Temp. 7°CDB / 6°CWB, Leaving Water Temp. 35°C
 - Cooling : Outdoor Temp. 35°C(DB) / 24°C(WB), Leaving Water Temp. 18°C
- All installation sites must be equipped with an earth leakage circuit breaker (ELCB).
 - * DHW 55~80°C Operating is available only when the booster heater is operating.
 - ** This is the power input i accordance with the 80% pump capacity setting at rated water flow rate. When the OH SUNG pump is set as 80% capacity, it's head is similar to that of the GRUNDFOS pump at rated water flow rate.
 - # This operation range includes not only the continuous operation range but also operative range.

2. Specification

■ Backup Heater

Electrical Specification			AHEH036A [HA031M E1] AHEH036D [HA031M E2]	AHEH066A [HA061M E1] AHEH066D [HA061M E2]	AHEH068A [HA063M E1] AHEH068D [HA063M E2]
Backup Heater	Type	-	Sheath	Sheath	Sheath
	Number of Heating Coil	EA	1	2	3
	Capacity Combination	kW	3.0	3.0 + 3.0	2.0 + 2.0 + 2.0
	Operation	-	Automatic	Automatic	Automatic
	Heating Steps	Step	1	2	1
	Power Supply	V, Ø, Hz	220-240, 1, 50	220-240, 1, 50	380-415, 3, 50
	Rated Running Current	A	12.5	25	8.7
Wiring Connections	Circuit Breaker	A	25	40	25
	Power Cable (Included Earth, H07RN-F)	mm ² x cores	1.5 x 3C	4.0 x 3C	2.5 x 4C
	Communication Cable (H07RN-F)	mm ² x cores	0.75 x 2C	0.75 x 4C	0.75 x 2C

Note

1. Due to our policy of innovation some specifications may be changed without notification.
2. Wiring cable size must comply with the applicable local and national codes. And "Electric characteristics" chapter should be considered for electrical work and design. Especially the power cable and circuit breaker should be selected in accordance with that.

3. Dimensions

Product

- ◆ ZHBW056A2 [HM051MRS UA40] / ZHBW076A2 [HM071MRS UA40] / ZHBW096A2 [HM091MRS UA40]

[Unit : mm]
Chassis code : UN36A
P/No. : TBW30101501_Rev 00

1242
761
236
391
330
421

853
35

414
405
369
324
104
42
213

3D VIEW

17 Automatic Air vents
16 Water Pressure Sensor
15 Flow sensor
14 Outdoor Control Box
13 Indoor Control Box
12 Safety relief valve
11 Compressor shield panel
10 Plate Heat Exchanger
9 Water Pump
8 UNIT Power
7 Low Voltage
6 Side Panel
5 Front Panel
4 Top cover
3 Air discharge Grille
2 Leaving water pipe
1 Entering water pipe
No. Part Name Description

SENSATA 2HMP3-05W 02-MPa
SIKA VVX20 / SEBA LCF-080-C20-E-C0.5V, 5-80 LPM
Inverter PCB and terminal blocks
Hydro, Cycle PCB and terminal blocks
Open at water pressure 3 bar
-
Heat exchange between refrigerant and water
OH SUNG, ODM-06IP / GRUNDFOS, UPM3K 20-75 CHBL
Power Cable Hole
Communication Cable Hole
-
-
-
Male PT 1" according to ISO 7-1 (tapered pipe threads)
Male PT 1" according to ISO 7-1 (tapered pipe threads)
Description

Drain holes for drain cap (7EA)
Note.
If you need more drains, remove them.

4-holes for anchor bolts(M10)
Drain hole for drain nipple (1EA)

3. Dimensions

- ◆ ZHBW126A2 [HM121MRS UB40] / ZHBW146A2 [HM121MRS UB40] / ZHBW166A2 [HM161MRS UB40] / ZHBW128A2 [HM123MRS UB40] / ZHBW148A2 [HM143MRS UB40] / ZHBW168A2 [HM163MRS UB40]

[Unit : mm]
Chassis code : UN368
P/No. : TBW30101801_Rev 00

1320
718
302
520
460
556

1019
24

413
405
368
323
104
40
214

3D VIEW

17 Automatic Air vent
16 Water Pressure Sensor
15 Flow sensor
14 Outdoor Control Box
13 Indoor Control Box
12 Safety relief valve
11 Compressor sound proof
10 Plate Heat Exchanger
9 Water Pump
8 UNIT Power
7 Low Voltage
6 Side Panel
5 Front Panel
4 Top cover
3 Air discharge Grille
2 Leaving water pipe
1 Entering water pipe

17
16
15
14
13
12
11
10
9
8
7
6
5
4
3
2
1

Drain holes for drain cap (7EA)
Note.
If you need more drains, remove them.

4-holes for anchor bolts(M10)
Drain hole for drain nipple (1EA)

No.	Part Name	Description
17	Automatic Air vent	-
16	Water Pressure Sensor	SENSATA 2HMP3-05W 02-MPa
15	Flow sensor	SIKA VHX20 / SEBA LGF-080-C20-E-00.5V, 5-60 LPM
14	Outdoor Control Box	Inverter PCB and terminal blocks
13	Indoor Control Box	Hydro, Cycle PCB and terminal blocks
12	Safety relief valve	Open at water pressure 3 bar
11	Compressor sound proof	-
10	Plate Heat Exchanger	Heat exchange between refrigerant and water
9	Water Pump	OH SUNG, ODM-061P / GRUNDFOS, UPM3K 20-75 CHBL
8	UNIT Power	Power Cable Hole
7	Low Voltage	Communication Cable Hole
6	Side Panel	-
5	Front Panel	-
4	Top cover	-
3	Air discharge Grille	-
2	Leaving water pipe	Male PT 1" according to ISO 7-1 (tapered pipe threads)
1	Entering water pipe	Male PT 1" according to ISO 7-1 (tapered pipe threads)
No.	Part Name	Description

3. Dimensions

Backup Heater

[Unit : mm]
P/No. : TAY37568301

Accessory(Backup Heater)

- Note**
 1. Unit should be installed in compliance with the installation manual in the product box.
 2. Unit should be grounded in accordance with the local regulations or applicable national codes.
 3. The electrical components and materials to be supplied from the site must comply with the local regulations or international codes.

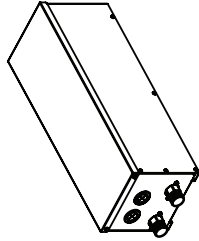
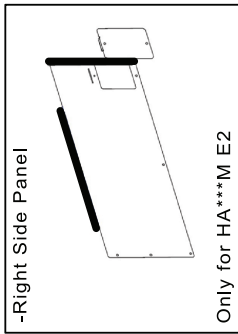

3D View

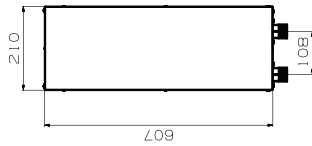

Side View

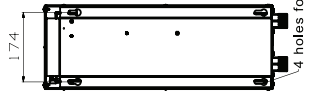

4 holes for Anchor Bolts (M8)

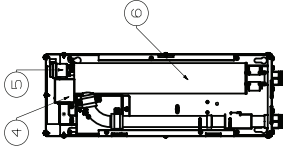
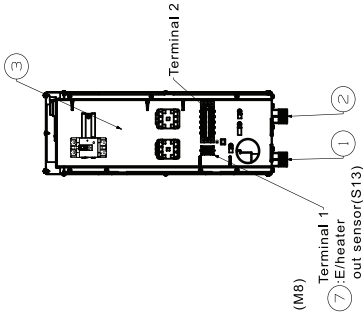

Side View

7	Backup heater outlet sensor(S13)	Connect to unit(heat pump)
6	Electric Heater	Refer the related information
5	Air vent	Air purging when charging water
4	Thermal switch	Cut-off power input to E/Heataer at 90°C
3	Control Box	Circuit Breaker, Magnetic Switch, Terminal Blocks
2	Entering Water Pipe	Male PT 1 inch
1	Leaving Water Pipe	Male PT 1 inch
No.	Part Name	Description

4. Piping Diagram

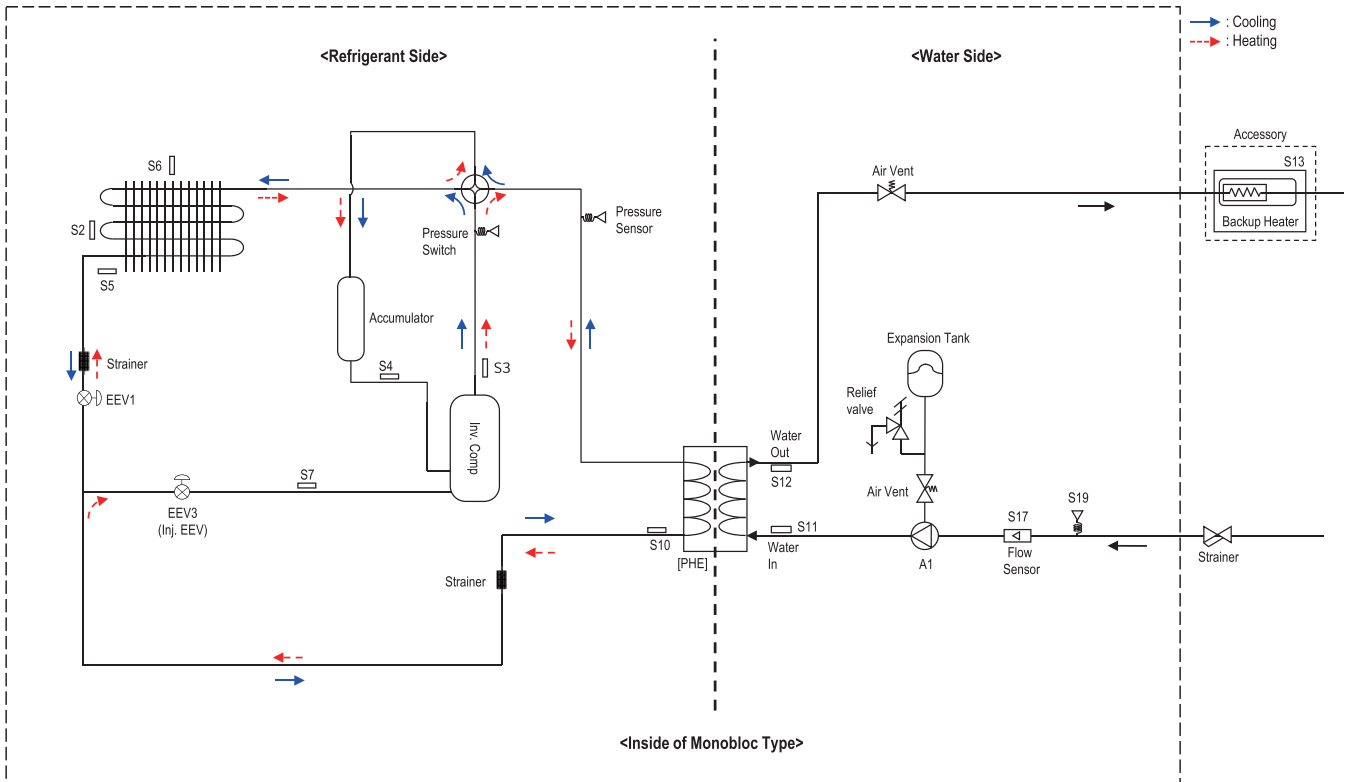

Category	Symbol	Meaning	PCB Connector
Refrigerant side	S10	PHEX liquid temp. sensor	CN_PIPE/IN
	S7	Compressor-injection pipe temperature sensor	CN_VI_IN
	S3	Compressor-discharge pipe temperature sensor	CN_DISCHA
	S4	Compressor-suction pipe temperature sensor	CN_SUCTION
	S2	Outdoor-HEX middle temp. sensor	CN_MID
	S5	Outdoor-HEX temp. sensor	CN_C_PIPE
	S6	Outdoor air temperature sensor	CN_AIR
	EEV1	Electronic Expansion Valve (Heating&Cooling)	CN_EEV1(WH)
EEV3	Electronic Expansion Valve (Injection)	CN_EEV3(YL)	
Water Side	S11	Inlet water temperature sensor	CN_TH3
	S12	Outlet water temperature sensor	
	S13	Electric backup heater outlet (Accessory kit)	
	S17	Flow sensor	CN_F_SENSOR
	S19	Water pressure sensor	CN_H20_PRESS
A1	Main Water Pump	CN_PUMP_A1	

5. Wiring Diagram

◆ ZHBW056A2 [HM051MRS UA40] / ZHBW076A2 [HM071MRS UA40] / ZHBW096A2 [HM091MRS UA40]

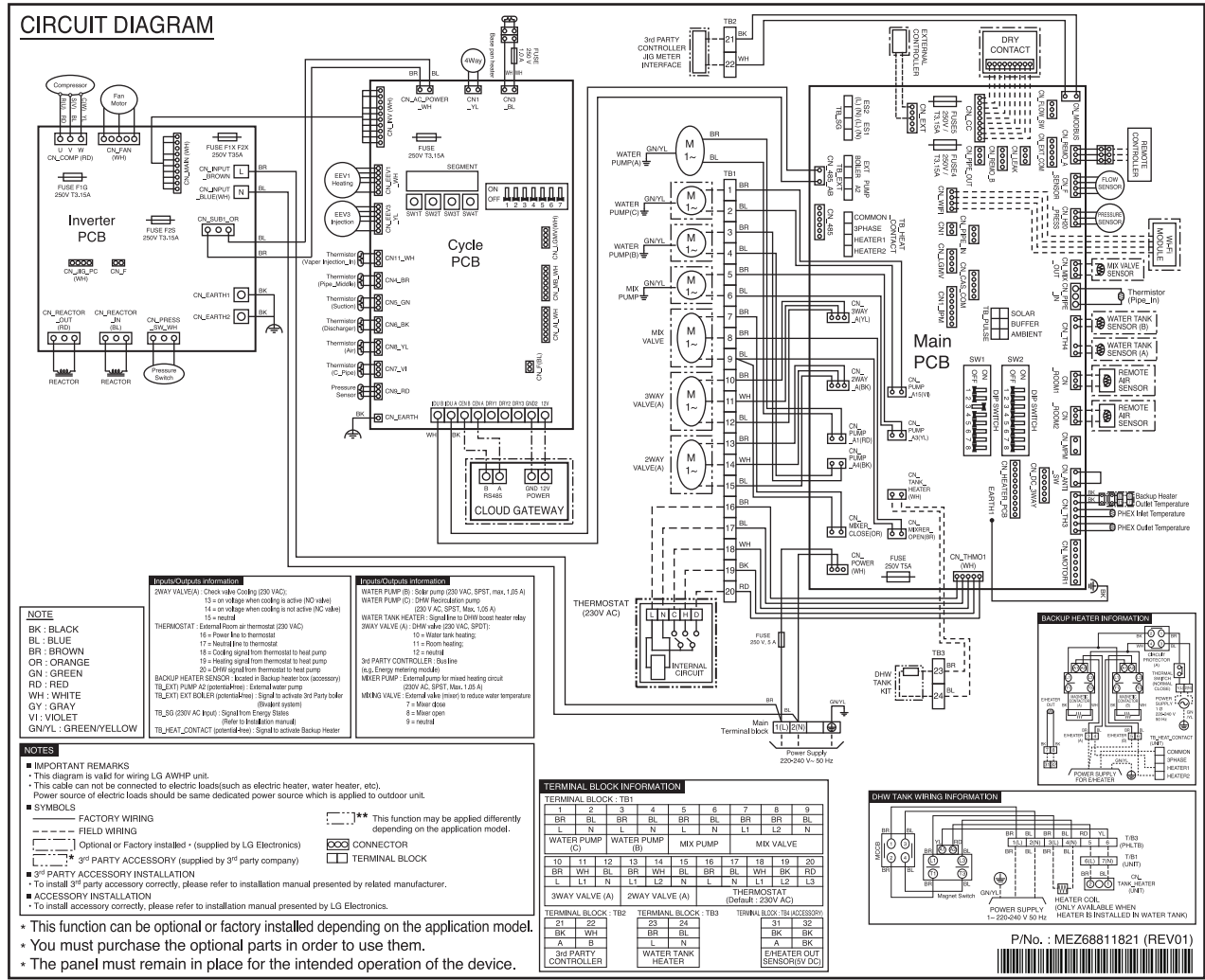

5. Wiring Diagram

◆ ZHBW126A2 [HM121MRS UB40] / ZHBW146A2 [HM141MRS UB40] / ZHBW166A2 [HM161MRS UB40]

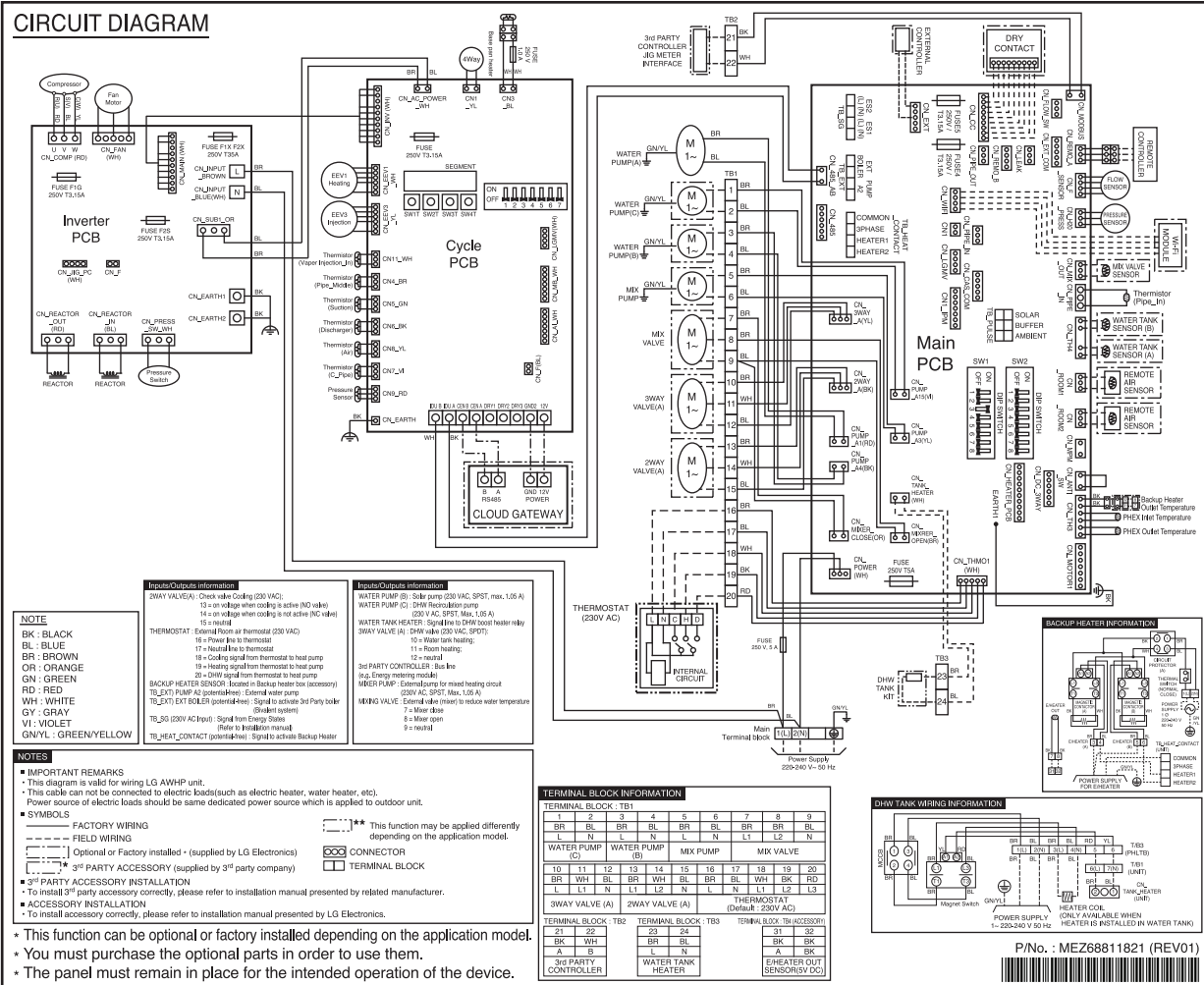

5. Wiring Diagram

◆ ZHBW128A2 [HM123MRS UB40] / ZHBW148A2 [HM143MRS UB40] / ZHBW168A2 [HM163MRS UB40]

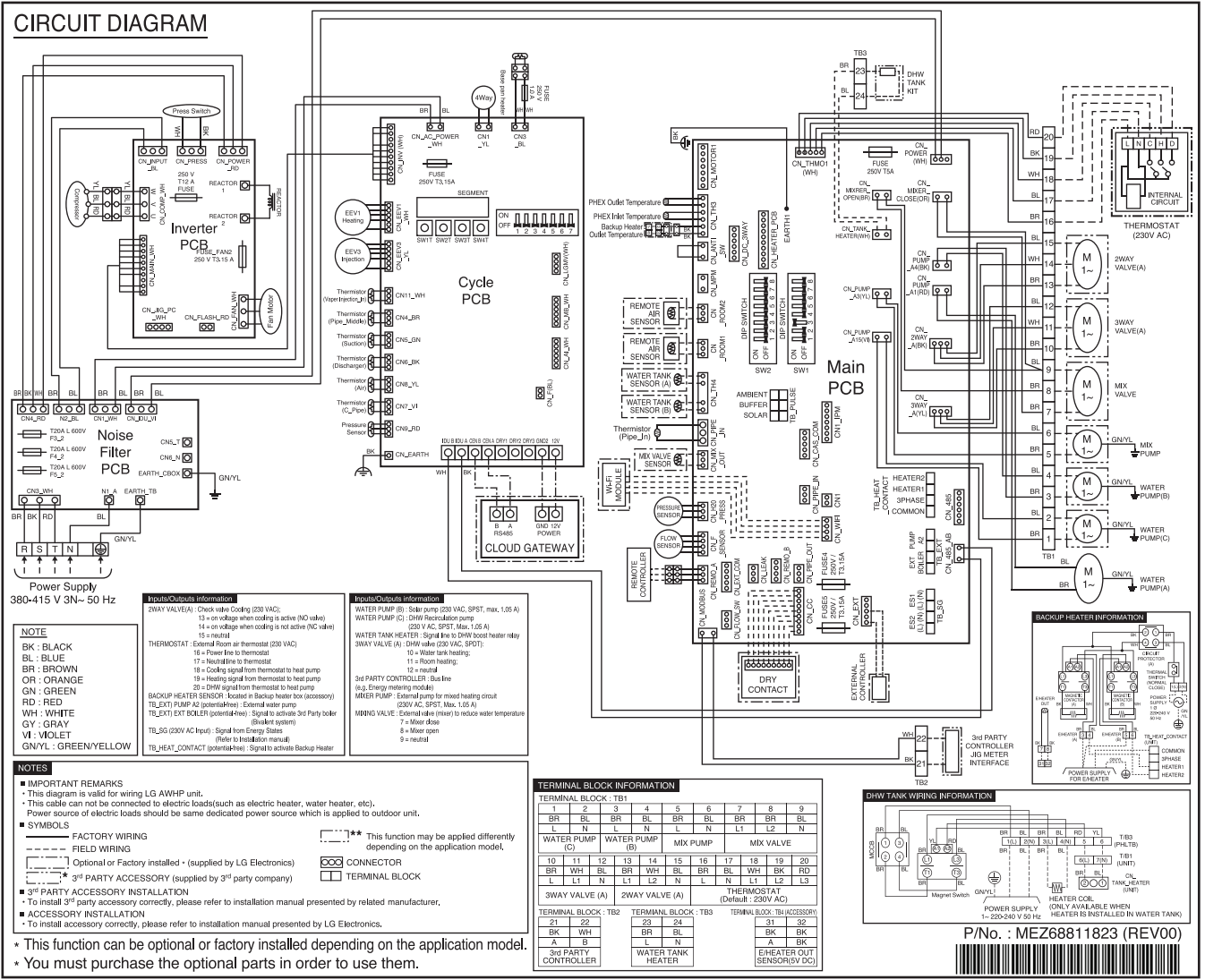

6. Performance Data

6.1 Cooling Operation

■ Maximum Cooling Capacity

◆ ZHBW056A2 [HM051MRS UA40]

Outdoor Temperature [°C DB]	Water flow rate 15.81 LPM													
	LWT 7 °C		LWT 10 °C		LWT 13 °C		LWT 15 °C		LWT 18 °C		LWT 20 °C		LWT 22 °C	
	TC	EER	TC	EER	TC	EER	TC	EER	TC	EER	TC	EER	TC	EER
10	5.50	5.27	5.50	5.97	5.50	6.45	5.50	6.84	5.50	7.43	5.50	7.83	5.50	8.22
20	5.50	4.48	5.50	5.05	5.50	5.44	5.50	5.76	5.50	6.24	5.50	6.56	5.50	6.88
30	5.50	3.18	5.50	3.70	5.50	4.07	5.50	4.37	5.50	4.81	5.50	5.11	5.50	5.40
35	5.50	3.30	5.50	3.67	5.50	3.92	5.50	4.13	5.50	4.70	5.50	4.65	5.50	4.86
40	5.29	2.66	5.32	3.00	5.36	3.24	5.38	3.44	5.41	3.73	5.43	3.93	5.45	4.13
45	5.09	2.01	5.15	2.34	5.21	2.56	5.25	2.75	5.31	3.02	5.36	3.21	5.40	3.39

◆ ZHBW076A2 [HM071MRS UA40]

Outdoor Temperature [°C DB]	Water flow rate 20.12 LPM													
	LWT 7 °C		LWT 10 °C		LWT 13 °C		LWT 15 °C		LWT 18 °C		LWT 20 °C		LWT 22 °C	
	TC	EER	TC	EER	TC	EER	TC	EER	TC	EER	TC	EER	TC	EER
10	7.00	4.91	7.00	5.65	7.00	6.17	7.00	6.59	7.00	7.21	7.00	7.63	7.00	8.05
20	7.00	4.23	7.00	4.82	7.00	5.23	7.00	5.56	7.00	6.07	7.00	6.40	7.00	6.74
30	7.00	3.54	7.00	3.98	7.00	4.29	7.00	4.54	7.00	4.92	7.00	5.17	7.00	5.42
35	7.00	3.20	7.00	3.57	7.00	3.82	7.00	4.03	7.00	4.50	7.00	4.55	7.00	4.76
40	6.36	2.60	6.45	2.94	6.55	3.17	6.61	3.36	6.71	3.65	6.77	3.84	6.84	4.04
45	5.71	1.99	5.82	2.30	5.92	2.52	5.99	2.70	6.10	2.96	6.17	3.14	6.24	3.31

◆ ZHBW096A2 [HM091MRS UA40]

Outdoor Temperature [°C DB]	Water flow rate 25.87 LPM													
	LWT 7 °C		LWT 10 °C		LWT 13 °C		LWT 15 °C		LWT 18 °C		LWT 20 °C		LWT 22 °C	
	TC	EER	TC	EER	TC	EER	TC	EER	TC	EER	TC	EER	TC	EER
10	9.00	4.55	9.00	5.34	9.00	5.89	9.00	6.33	9.00	7.00	9.00	7.44	9.00	7.89
20	9.00	3.97	9.00	4.59	9.00	5.02	9.00	5.37	9.00	5.90	9.00	6.25	9.00	6.60
30	9.00	3.39	9.00	3.84	9.00	4.16	9.00	4.41	9.00	4.79	9.00	5.05	9.00	5.31
35	9.00	3.10	9.00	3.47	9.00	3.72	9.00	3.93	9.00	4.20	9.00	4.45	9.00	4.66
40	7.66	2.54	7.66	2.87	7.65	3.10	7.65	3.29	7.65	3.57	7.65	3.76	7.65	3.95
45	6.31	1.98	6.35	2.27	6.39	2.48	6.42	2.65	6.45	2.90	6.48	3.07	6.51	3.23

Note

1. DB : Dry bulb temperature(°C), LWT : Leaving water temperature(°C), LPM : Liter per minute (ℓ/min)
2. TC : Total capacity(kW), EER: Energy efficiency ratio(kW/kW), COP : Coefficient of performance (kW/kW)
3. Direct interpolation is permissible. Do not extrapolate.
4. Measuring procedure follows EN14511.
 - Rated values are based on standard conditions, and it can be found on specifications.
 - Above table values may not be matched according to installation condition. Except for rated value, the performance is not guaranteed.
 - In accordance with the test standard(or nations), the results may vary.
5. The Shaded areas are not guaranteed continuous operation.

6. Performance Data

◆ ZHBW126A2 [HM121MRS UB40] / ZHBW128A2 [HM123MRS UB40]

Outdoor Temperature [°C DB]	Water flow rate 34.5 LPM													
	LWT 7 °C		LWT 10 °C		LWT 13 °C		LWT 15 °C		LWT 18 °C		LWT 20 °C		LWT 22 °C	
	TC	EER	TC	EER	TC	EER	TC	EER	TC	EER	TC	EER	TC	EER
10	12.00	5.22	12.00	5.60	12.00	5.87	12.00	6.09	12.00	6.42	12.00	6.64	12.00	6.85
20	12.00	4.45	12.00	4.78	12.00	5.02	12.00	5.20	12.00	5.49	12.00	5.67	12.00	5.86
30	12.00	3.68	12.00	3.96	12.00	4.16	12.00	4.32	12.00	4.55	12.00	4.71	12.00	4.87
35	12.00	3.30	12.00	3.55	12.00	3.73	12.00	3.87	12.00	4.75	12.00	4.23	12.00	4.38
40	11.05	2.81	11.19	3.06	11.33	3.23	11.43	3.37	11.57	3.58	11.67	3.72	11.76	3.85
45	10.10	2.33	10.37	2.57	10.64	2.73	10.83	2.86	11.10	3.07	11.28	3.20	11.46	3.33

◆ ZHBW146A2 [HM141MRS UB40] / ZHBW148A2 [HM143MRS UB40]

Outdoor Temperature [°C DB]	Water flow rate 40.3 LPM													
	LWT 7 °C		LWT 10 °C		LWT 13 °C		LWT 15 °C		LWT 18 °C		LWT 20 °C		LWT 22 °C	
	TC	EER	TC	EER	TC	EER	TC	EER	TC	EER	TC	EER	TC	EER
10	12.50	4.93	12.80	5.33	13.10	5.61	13.30	5.84	13.60	6.18	13.80	6.40	14.00	6.63
20	14.00	4.28	14.00	4.61	14.00	4.84	14.00	5.03	14.00	5.31	14.00	5.50	14.00	5.69
30	14.00	3.63	14.00	3.89	14.00	4.08	14.00	4.23	14.00	4.45	14.00	4.60	14.00	4.75
35	14.00	3.30	14.00	3.53	14.00	3.69	14.00	3.82	14.00	4.30	14.00	4.15	14.00	4.28
40	12.35	2.81	12.60	3.04	12.84	3.20	13.01	3.32	13.26	3.52	13.42	3.64	13.59	3.77
45	10.69	2.32	11.19	2.54	11.69	2.70	12.02	2.82	12.51	3.01	12.84	3.14	13.17	3.26

◆ ZHBW166A2 [HM161MRS UB40] / ZHBW168A2 [HM163MRS UB40]

Outdoor Temperature [°C DB]	Water flow rate 46.0 LPM													
	LWT 7 °C		LWT 10 °C		LWT 13 °C		LWT 15 °C		LWT 18 °C		LWT 20 °C		LWT 22 °C	
	TC	EER	TC	EER	TC	EER	TC	EER	TC	EER	TC	EER	TC	EER
10	13.00	4.64	13.60	5.05	14.20	5.35	14.60	5.58	15.20	5.94	15.60	6.17	16.00	6.41
20	16.00	4.02	16.00	4.37	16.00	4.61	16.00	4.81	16.00	5.10	16.00	5.30	16.00	5.50
30	16.00	3.41	16.00	3.68	16.00	3.88	16.00	4.03	16.00	4.27	16.00	4.42	16.00	4.58
35	16.00	3.10	16.00	3.34	16.00	3.51	16.00	3.65	16.00	4.00	16.00	3.99	16.00	4.12
40	13.60	2.70	13.96	2.92	14.32	3.08	14.56	3.20	14.92	3.39	15.16	3.52	15.40	3.64
45	11.20	2.29	11.76	2.50	12.32	2.64	12.69	2.76	13.25	2.93	13.62	3.05	14.00	3.16

Note

1. DB : Dry bulb temperature(°C), LWT : Leaving water temperature(°C), LPM : Liter per minute (l/min)
2. TC : Total capacity(kW), EER: Energy efficiency ratio(kW/kW), COP : Coefficient of performance (kW/kW)
3. Direct interpolation is permissible. Do not extrapolate.
4. Measuring procedure follows EN14511.
 - Rated values are based on standard conditions, and it can be found on specifications.
 - Above table values may not be matched according to installation condition. Except for rated value, the performance is not guaranteed.
 - In accordance with the test standard(or nations), the results may vary.
5. The Shaded areas are not guaranteed continuous operation.

6. Performance Data

6.2 Heating Operation

■ Maximum Heating Capacity (Include defrost effect)

◆ ZHBW056A2 [HM051MRS UA40]

Outdoor Temperature	Water flow rate 15.81 LPM								Water flow rate 9.9 LPM				Water flow rate 7.9 LPM				
	LWT 30°C		LWT 35°C		LWT 40°C		LWT 45°C		LWT 50°C		LWT 55°C		LWT 60°C		LWT 65°C		
	TC	COP	TC	COP	TC	COP	TC	COP	TC	COP	TC	COP	TC	COP	TC	COP	
-25 °C DB	5.50	2.02	5.50	1.88	5.50	1.74	5.50	1.60									
-20 °C DB	5.50	2.57	5.50	2.38	5.50	2.19	5.50	2.00	5.23	1.82							
-15 °C DB	5.50	2.71	5.50	2.50	5.50	2.33	5.50	2.16	5.23	2.04	5.23	1.93					
-7 °C DB	5.50	3.15	5.50	2.95	5.50	2.63	5.50	2.30	5.50	2.15	5.50	1.99	5.50	1.93			
-4 °C DB	5.50	3.31	5.50	3.12	5.50	2.93	5.50	2.77	5.50	2.58	5.50	2.39	5.50	2.10	5.50	1.93	
-2 °C DB	5.50	3.46	5.50	3.23	5.50	3.04	5.50	2.84	5.50	2.66	5.50	2.48	5.50	2.21	5.50	2.03	
2 °C DB	5.50	3.64	5.50	3.46	5.50	3.26	5.50	3.05	5.50	2.85	5.50	2.64	5.50	2.44	5.50	2.24	
7 °C DB	5.50	5.02	5.50	4.70	5.50	4.15	5.50	3.59	5.50	3.23	5.50	2.86	5.50	2.68	5.50	2.49	
10 °C DB	5.50	5.87	5.50	5.41	5.50	4.69	5.50	3.97	5.50	3.55	5.50	3.57	5.50	3.11	5.50	2.64	
15 °C DB	5.50	6.43	5.50	5.92	5.50	5.21	5.50	4.50	5.50	4.03	5.50	3.91	5.50	3.40	5.50	2.90	
18 °C DB	5.50	6.76	5.50	6.23	5.50	5.52	5.50	4.82	5.50	4.32	5.50	4.11	5.50	3.58	5.50	3.05	
20 °C DB	5.50	6.98	5.50	6.43	5.50	5.73	5.50	5.03	5.50	4.51	5.50	4.25	5.50	3.70	5.50	3.15	
35 °C DB	5.50	8.65	5.50	7.97	5.50	7.30	5.50	6.62	5.50	5.95	5.50	5.27	5.50	4.60	5.50	3.92	

◆ ZHBW076A2 [HM071MRS UA40]

Outdoor Temperature	Water flow rate 20.12 LPM								Water flow rate 12.6 LPM				Water flow rate 10.0 LPM				
	LWT 30°C		LWT 35°C		LWT 40°C		LWT 45°C		LWT 50°C		LWT 55°C		LWT 60°C		LWT 65°C		
	TC	COP	TC	COP	TC	COP	TC	COP	TC	COP	TC	COP	TC	COP	TC	COP	
-25 °C DB	5.85	1.98	5.85	1.84	5.85	1.69	5.85	1.55									
-20 °C DB	6.43	2.53	6.43	2.34	6.43	2.15	6.43	1.96	6.10	1.76							
-15 °C DB	7.00	2.68	7.00	2.45	7.00	2.28	7.00	2.11	6.65	2.00	6.65	1.89					
-7 °C DB	7.00	3.16	7.00	2.92	7.00	2.58	7.00	2.24	7.00	2.10	7.00	1.95	7.00	1.89			
-4 °C DB	7.00	3.35	7.00	3.09	7.00	2.89	7.00	2.73	7.00	2.54	7.00	2.35	7.00	2.06	7.00	1.89	
-2 °C DB	7.00	3.50	7.00	3.20	7.00	3.00	7.00	2.80	7.00	2.62	7.00	2.44	7.00	2.17	7.00	1.99	
2 °C DB	7.00	3.56	7.00	3.43	7.00	3.22	7.00	3.02	7.00	2.81	7.00	2.61	7.00	2.40	7.00	2.20	
7 °C DB	7.00	4.97	7.00	4.70	7.00	4.11	7.00	3.52	7.00	3.17	7.00	2.81	7.00	2.63	7.00	2.45	
10 °C DB	7.00	5.83	7.00	5.37	7.00	4.62	7.00	3.86	7.00	3.46	7.00	3.53	7.00	3.06	7.00	2.60	
15 °C DB	7.00	6.38	7.00	5.88	7.00	5.14	7.00	4.41	7.00	3.95	7.00	3.87	7.00	3.36	7.00	2.86	
18 °C DB	7.00	6.72	7.00	6.19	7.00	5.46	7.00	4.73	7.00	4.24	7.00	4.07	7.00	3.54	7.00	3.01	
20 °C DB	7.00	6.94	7.00	6.39	7.00	5.67	7.00	4.95	7.00	4.43	7.00	4.21	7.00	3.66	7.00	3.11	
35 °C DB	7.00	8.60	7.00	7.93	7.00	7.25	7.00	6.58	7.00	5.90	7.00	5.23	7.00	4.55	7.00	3.88	

◆ ZHBW096A2 [HM091MRS UA40]

Outdoor Temperature	Water flow rate 25.87 LPM								Water flow rate 16.2 LPM				Water flow rate 12.9 LPM				
	LWT 30°C		LWT 35°C		LWT 40°C		LWT 45°C		LWT 50°C		LWT 55°C		LWT 60°C		LWT 65°C		
	TC	COP	TC	COP	TC	COP	TC	COP	TC	COP	TC	COP	TC	COP	TC	COP	
-25 °C DB	6.20	1.97	6.20	1.82	6.20	1.68	6.20	1.53									
-20 °C DB	7.60	2.50	7.60	2.31	7.60	2.12	7.60	1.93	7.22	1.74							
-15 °C DB	9.00	2.64	9.00	2.43	9.00	2.25	9.00	2.07	8.55	1.96	8.55	1.80					
-7 °C DB	9.00	3.06	9.00	2.89	9.00	2.68	9.00	2.19	9.00	2.10	9.00	1.84	9.00	1.82			
-4 °C DB	9.00	3.22	9.00	3.05	9.00	2.84	9.00	2.67	9.00	2.48	9.00	2.29	9.00	2.00	9.00	1.85	
-2 °C DB	9.00	3.46	9.00	3.15	9.00	2.94	9.00	2.75	9.00	2.57	9.00	2.38	9.00	2.12	9.00	1.95	
2 °C DB	9.00	3.53	9.00	3.36	9.00	3.16	9.00	2.95	9.00	2.75	9.00	2.55	9.00	2.35	9.00	2.15	
7 °C DB	9.00	4.89	9.00	4.60	9.00	4.04	9.00	3.48	9.00	3.12	9.00	2.76	9.00	2.58	9.00	2.40	
10 °C DB	9.00	5.46	9.00	5.27	9.00	4.48	9.00	3.70	9.00	3.41	9.00	3.46	9.00	3.00	9.00	2.55	
15 °C DB	9.00	6.05	9.00	5.77	9.00	5.01	9.00	4.25	9.00	3.88	9.00	3.79	9.00	3.29	9.00	2.80	
18 °C DB	9.00	6.41	9.00	6.07	9.00	5.32	9.00	4.58	9.00	4.17	9.00	3.99	9.00	3.47	9.00	2.95	
20 °C DB	9.00	6.64	9.00	6.27	9.00	5.53	9.00	4.80	9.00	4.36	9.00	4.12	9.00	3.59	9.00	3.05	
35 °C DB	9.00	8.43	9.00	7.77	9.00	7.11	9.00	6.44	9.00	5.78	9.00	5.12	9.00	4.46	9.00	3.80	

Note

1. DB : Dry bulb temperature(°C), LWT : Leaving water temperature(°C), LPM : Liter per minute (ℓ/min)
2. TC : Total capacity(kW), EER: Energy efficiency ratio(kW/kW), COP : Coefficient of performance (kW/kW)
3. Direct interpolation is permissible. Do not extrapolate.
4. Measuring procedure follows EN14511.
 - Rated values are based on standard conditions, and it can be found on specifications.
 - Above table values may not be matched according to installation condition. Except for rated value, the performance is not guaranteed.
 - In accordance with the test standard(or nations), the results may vary.
5. The Shaded areas are not guaranteed continuous operation.

6. Performance Data

◆ ZHBW126A2 [HM121MRS UB40] / ZHBW128A2 [HM123MRS UB40]

Outdoor Temperature	Water flow rate 34.5 LPM								Water flow rate 21.6 LPM				Water flow rate 17.3 LPM			
	LWT 30°C		LWT 35°C		LWT 40°C		LWT 45°C		LWT 50°C		LWT 55°C		LWT 60°C		LWT 65°C	
	TC	COP	TC	COP	TC	COP	TC	COP	TC	COP	TC	COP	TC	COP	TC	COP
-25 °C DB	9.50	2.13	9.50	1.97	9.50	1.81	9.50	1.65								
-20 °C DB	10.75	2.68	10.75	2.47	10.75	2.27	10.75	2.07	10.21	1.87						
-15 °C DB	12.00	2.77	12.00	2.55	12.00	2.34	12.00	2.14	11.50	2.07	11.50	2.00				
-7 °C DB	12.00	3.22	12.00	3.16	12.00	2.82	12.00	2.44	12.00	2.26	12.00	2.08	12.00	2.03		
-4 °C DB	12.00	3.39	12.00	3.29	12.00	3.00	12.00	2.68	12.00	2.49	12.00	2.31	12.00	2.21	12.00	2.06
-2 °C DB	12.00	3.50	12.00	3.38	12.00	3.11	12.00	2.84	12.00	2.65	12.00	2.46	12.00	2.32	12.00	2.16
2 °C DB	12.00	3.73	12.00	3.55	12.00	3.35	12.00	3.15	12.00	2.95	12.00	2.76	12.00	2.56	12.00	2.36
7 °C DB	12.00	5.15	12.00	4.90	12.00	4.37	12.00	3.83	12.00	3.50	12.00	3.16	12.00	2.88	12.00	2.61
10 °C DB	12.00	5.82	12.00	5.29	12.00	4.76	12.00	4.24	12.00	3.76	12.00	3.67	12.00	3.21	12.00	2.76
15 °C DB	12.00	6.39	12.00	5.83	12.00	5.28	12.00	4.73	12.00	4.21	12.00	4.00	12.00	3.50	12.00	3.01
18 °C DB	12.00	6.73	12.00	6.16	12.00	5.59	12.00	5.02	12.00	4.48	12.00	4.20	12.00	3.68	12.00	3.15
20 °C DB	12.00	6.96	12.00	6.38	12.00	5.80	12.00	5.21	12.00	4.66	12.00	4.34	12.00	3.80	12.00	3.25
35 °C DB	12.00	8.68	12.00	8.01	12.00	7.34	12.00	6.68	12.00	6.01	12.00	5.34	12.00	4.67	12.00	4.00

◆ ZHBW146A2 [HM141MRS UB40] / ZHBW148A2 [HM143MRS UB40]

Outdoor Temperature	Water flow rate 40.25 LPM								Water flow rate 25.2 LPM				Water flow rate 20.1 LPM			
	LWT 30°C		LWT 35°C		LWT 40°C		LWT 45°C		LWT 50°C		LWT 55°C		LWT 60°C		LWT 65°C	
	TC	COP	TC	COP	TC	COP	TC	COP	TC	COP	TC	COP	TC	COP	TC	COP
-25 °C DB	10.00	2.09	10.00	1.93	10.00	1.78	10.00	1.62								
-20 °C DB	12.00	2.62	12.00	2.42	12.00	2.23	12.00	2.03	11.40	1.83						
-15 °C DB	14.00	2.70	14.00	2.50	14.00	2.28	14.00	2.05	13.30	2.00	13.30	1.95				
-7 °C DB	14.00	3.24	14.00	2.83	14.00	2.76	14.00	2.25	14.00	2.16	14.00	2.06	14.00	1.98		
-4 °C DB	14.00	3.45	14.00	3.05	14.00	2.94	14.00	2.53	14.00	2.40	14.00	2.27	14.00	2.15	14.00	2.00
-2 °C DB	14.00	3.58	14.00	3.20	14.00	3.06	14.00	2.72	14.00	2.57	14.00	2.42	14.00	2.27	14.00	2.10
2 °C DB	14.00	3.85	14.00	3.50	14.00	3.30	14.00	3.10	14.00	2.90	14.00	2.70	14.00	2.50	14.00	2.30
7 °C DB	14.00	5.04	14.00	4.80	14.00	4.26	14.00	3.72	14.00	3.39	14.00	3.05	14.00	2.80	14.00	2.55
10 °C DB	14.00	5.65	14.00	5.11	14.00	4.57	14.00	4.02	14.00	3.66	14.00	3.60	14.00	3.15	14.00	2.70
15 °C DB	14.00	6.22	14.00	5.66	14.00	5.09	14.00	4.53	14.00	4.11	14.00	3.93	14.00	3.44	14.00	2.95
18 °C DB	14.00	6.56	14.00	5.99	14.00	5.41	14.00	4.84	14.00	4.38	14.00	4.13	14.00	3.61	14.00	3.10
20 °C DB	14.00	6.79	14.00	6.21	14.00	5.62	14.00	5.04	14.00	4.56	14.00	4.26	14.00	3.73	14.00	3.20
35 °C DB	14.00	8.52	14.00	7.86	14.00	7.21	14.00	6.56	14.00	5.91	14.00	5.25	14.00	4.60	12.50	3.95

◆ ZHBW166A2 [HM161MRS UB40] / ZHBW168A2 [HM163MRS UB40]

Outdoor Temperature	Water flow rate 46 LPM								Water flow rate 28.8 LPM				Water flow rate 23.0 LPM			
	LWT 30°C		LWT 35°C		LWT 40°C		LWT 45°C		LWT 50°C		LWT 55°C		LWT 60°C		LWT 65°C	
	TC	COP	TC	COP	TC	COP	TC	COP	TC	COP	TC	COP	TC	COP	TC	COP
-25 °C DB	10.50	1.96	10.50	1.84	10.50	1.72	10.50	1.60								
-20 °C DB	13.25	2.48	13.25	2.32	13.25	2.15	13.25	1.98	12.59	1.82						
-15 °C DB	16.00	2.58	14.40	2.45	14.40	2.23	14.40	2.01	13.68	1.97	13.68	1.94				
-7 °C DB	16.00	3.17	16.00	2.70	16.00	2.44	16.00	2.17	16.00	2.09	16.00	2.01	16.00	1.94		
-4 °C DB	16.00	3.35	16.00	2.93	16.00	2.69	16.00	2.45	16.00	2.34	16.00	2.22	16.00	2.11	16.00	1.95
-2 °C DB	16.00	3.47	16.00	3.09	16.00	2.86	16.00	2.64	16.00	2.50	16.00	2.36	16.00	2.22	16.00	2.05
2 °C DB	16.00	3.71	16.00	3.40	16.00	3.21	16.00	3.02	16.00	2.83	16.00	2.63	16.00	2.44	16.00	2.25
7 °C DB	16.00	4.88	16.00	4.70	16.00	4.16	16.00	3.61	16.00	3.26	16.00	2.91	16.00	2.71	16.00	2.50
10 °C DB	16.00	5.48	16.00	4.96	16.00	4.44	16.00	3.91	16.00	3.53	16.00	3.51	16.00	3.08	16.00	2.65
15 °C DB	16.00	6.06	16.00	5.51	16.00	4.96	16.00	4.42	16.00	3.99	16.00	3.84	16.00	3.37	16.00	2.90
18 °C DB	16.00	6.40	16.00	5.84	16.00	5.28	16.00	4.72	16.00	4.26	16.00	4.04	16.00	3.55	16.00	3.05
20 °C DB	16.00	6.63	16.00	6.06	16.00	5.49	16.00	4.92	16.00	4.44	16.00	4.18	16.00	3.66	16.00	3.15
35 °C DB	16.00	8.35	16.00	7.71	16.00	7.08	16.00	6.44	16.00	5.81	16.00	5.17	16.00	4.54	13.00	3.90

Note

1. DB : Dry bulb temperature(°C), LWT : Leaving water temperature(°C), LPM : Liter per minute (ℓ/min)
2. TC : Total capacity(kW), EER: Energy efficiency ratio(kW/kW), COP : Coefficient of performance (kW/kW)
3. Direct interpolation is permissible. Do not extrapolate.
4. Measuring procedure follows EN14511.
 - Rated values are based on standard conditions, and it can be found on specifications.
 - Above table values may not be matched according to installation condition. Except for rated value, the performance is not guaranteed.
 - In accordance with the test standard(or nations), the results may vary.
5. The Shaded areas are not guaranteed continuous operation.

7. Electric Characteristics

■ Wiring of Main Power Supply and Equipment Capacity

1. Bear in mind ambient conditions (ambient temperature, direct sunlight, rain liquid, etc.) when proceeding with the wiring and connections
 2. The wire size is the minimum value for metal conduit wiring. The power cord size should be 1 rank thicker taking into account the line voltage drops. Make sure the power-supply voltage does not drop more than 10%.
 3. Specific wiring requirements should adhere to the wiring regulations of the region.
 4. Power supply cords of parts of appliances for outdoor use should not be lighter than polychloroprene sheathed flexible cord.
 5. Don't install an individual switch or electrical outlet to disconnect each of indoor unit separately from the power supply.
-

WARNING

- Follow ordinance of your governmental organization for technical standard related to electrical equipment, wiring regulations and guidance of each electric power company.
 - Make sure to use specified wires for connections so that no external force is imparted to terminal connections. If connections are not fixed firmly, it may cause heating or fire.
 - Make sure to use the appropriate type of overcurrent protection switch. Note that generated overcurrent may include some amount of direct current.
-

CAUTION

- All installation site must require attachment of an earth leakage breaker. If no earth leakage breaker is installed, it may cause an electric shock.
 - Do not use anything other than breaker and fuse with correct capacity. Using fuse and wire or copper wire with too large capacity may cause a malfunction of unit or fire.
-

7. Electric Characteristics

Outdoor Unit	Phase / Volts / Hz	Voltage range
ZHBW056A2 [HM051MRS UA40]	1 Ø / 220-240 V / 50 Hz	Min. : 198 Max. : 264
ZHBW076A2 [HM071MRS UA40]		
ZHBW096A2 [HM091MRS UA40]		
ZHBW126A2 [HM121MRS UB40]	1 Ø / 220-240 V / 50 Hz	Min. : 198 Max. : 264
ZHBW146A2 [HM141MRS UB40]		
ZHBW166A2 [HM161MRS UB40]		
ZHBW128A2 [HM123MRS UB40]	3 Ø / 380-415 V / 50 Hz	Min. : 342 Max. : 457
ZHBW148A2 [HM143MRS UB40]		
ZHBW168A2 [HM163MRS UB40]		

Backup Heater	Power Supply for Heater	
	Phase / Volts / Hz	Capacity (kW)
AHEH036D [HA031M E2]	1 Ø / 220-240 V / 50 Hz	3
AHEH066D [HA061M E2]		3+3
AHEH068D [HA063M E2]	3 Ø / 380-415 V / 50 Hz	2+2+2

DHW Boost Heater	Power Supply for DHW Boost Heater	
	Phase / Volts / Hz	Capacity (kW)
Integral part of DHW tanks [OSHW-x00F(D)]	1 Ø / 220-240 V / 50 Hz	2.4

[Power Supply for Heat pump, Backup heater and DHW boost heater]

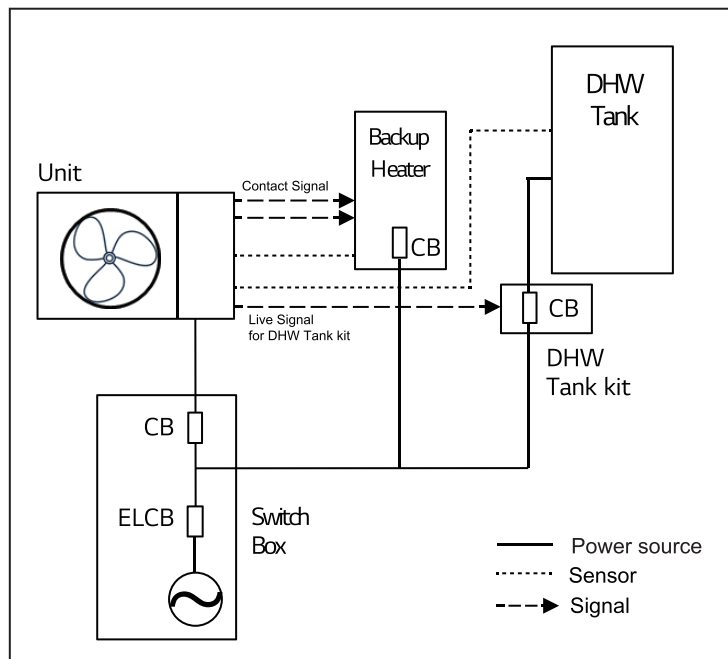

Note

1. Voltage supplied to the unit terminals should be within the minimum and maximum range.
2. Maximum allowable voltage unbalance between phase is 2%.

8. Operation Range

■ Cooling

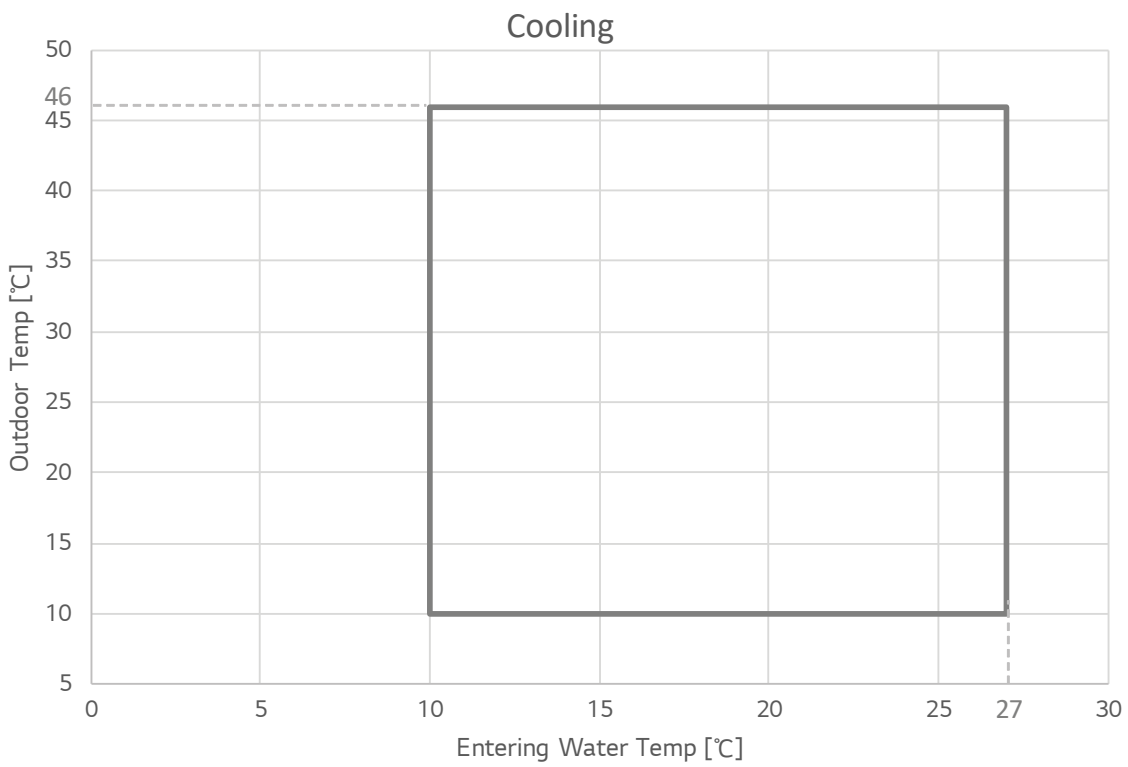
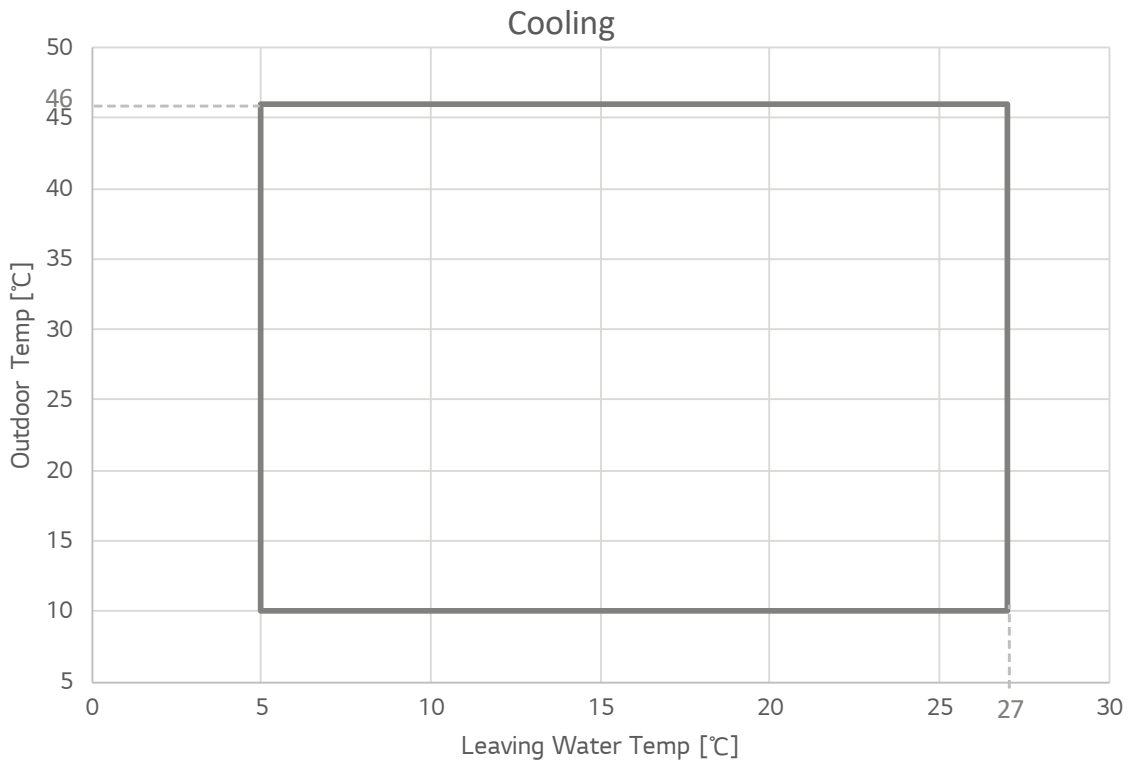

8. Operation Range

■ Heating

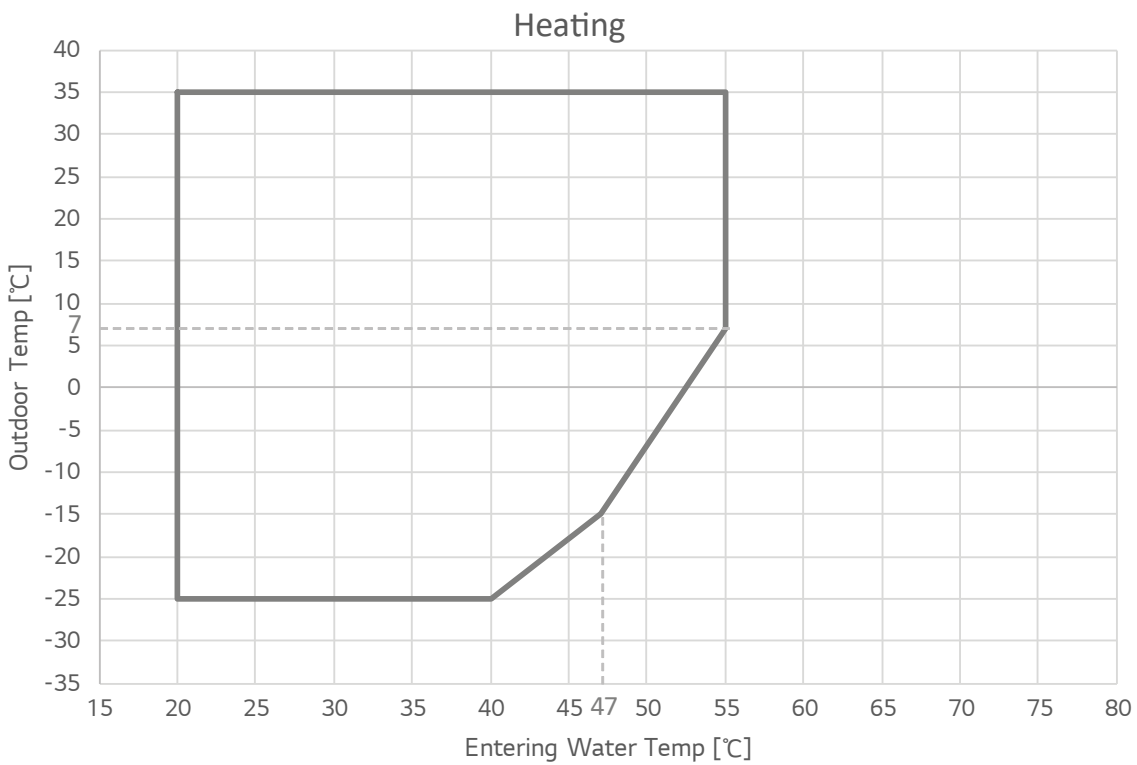
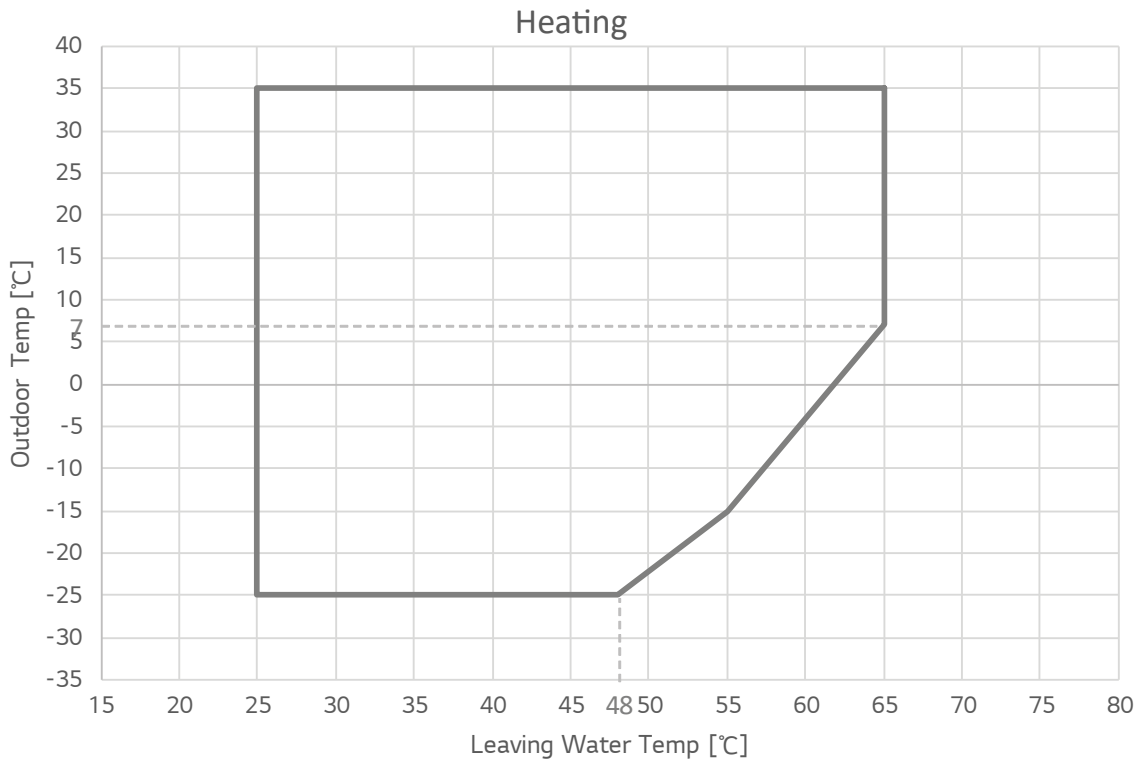

- DHW Heat pump operation : max. 55 °C
- DHW operation with booster heater : max. 80 °C

9. Sound levels

9.1 Sound power level

Note

1. Data is valid at diffuse field condition.
2. Reference acoustic intensity 0dB = 10E-6μW/m²
3. Sound power level is measured on the rated condition in the reverberation rooms. Refer to the Model Specifications for nominal conditions(Power source and Ambient temperature, etc)
4. Sound levels can be increased in accordance with installation and operating conditions.
5. Sound level will vary depending on a range of factors such as the construction (acoustic absorption coefficient) of particular installed place in which the equipment in installed.
6. Sound power level is measured in accordance with EN 12102-1 and ISO 9614.
 - Rated : This mode is measured on the rated condition in the semi-anechoic rooms. Therefore, these values may vary depending on operation conditions.
 - Daytime max : This mode is measured based on max. fan RPM and max. compressor Hz. that can be reached under outdoor air temperature 2°C.
 - Low noise : This mode lowers noise by limiting the compressor Hz. and fan RPM, and thus the performance may be limited.

Model	Heating [dB(A)]		
	Day max	Rated	Low noise
ZHBW056A2 [HM051MRS UA40]	63	57	54
ZHBW076A2 [HM071MRS UA40]	64	57	55
ZHBW096A2 [HM091MRS UA40]	64	57	55
ZHBW126A2 [HM121MRS UB40]	65	60	56
ZHBW146A2 [HM141MRS UB40]	66	61	57
ZHBW166A2 [HM161MRS UB40]	66	61	57
ZHBW128A2 [HM123MRS UB40]	65	60	56
ZHBW148A2 [HM143MRS UB40]	66	61	57
ZHBW168A2 [HM163MRS UB40]	66	61	57

ZHBW056A2 [HM051MRS UA40] ZHBW076A2 [HM071MRS UA40] ZHBW096A2 [HM091MRS UA40]

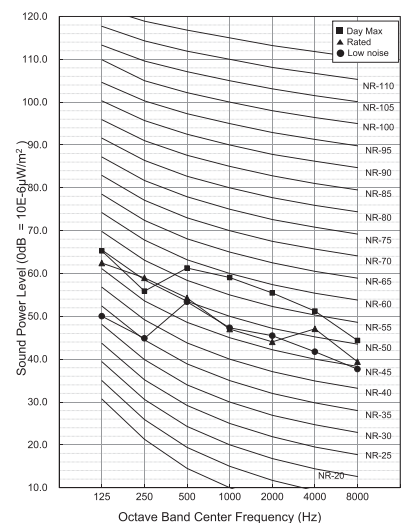
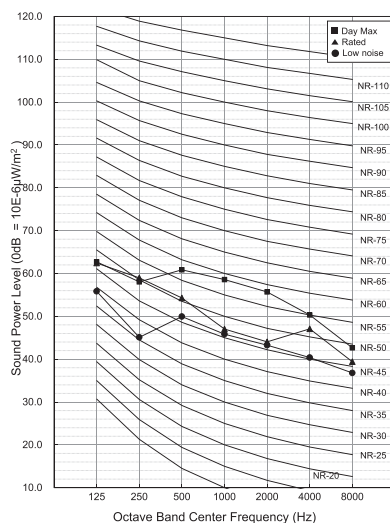
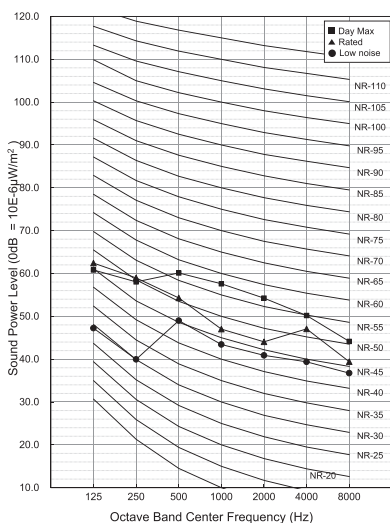

9. Sound levels

ZHBW126A2 [HM121MRS UB40]
ZHBW128A2 [HM123MRS UB40]

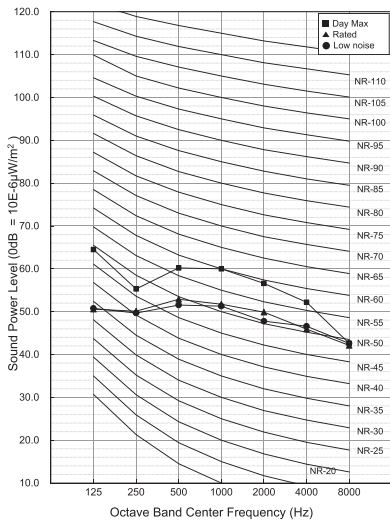

ZHBW146A2 [HM141MRS UB40]
ZHBW148A2 [HM143MRS UB40]

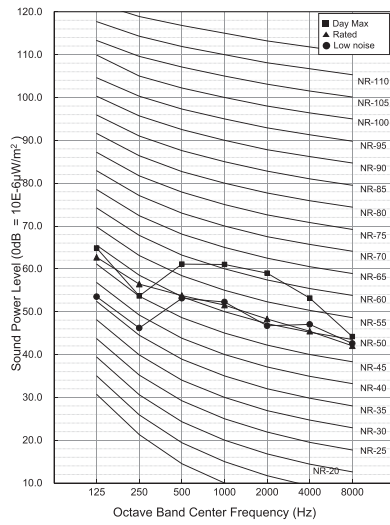

ZHBW166A2 [HM161MRS UB40]
ZHBW168A2 [HM163MRS UB40]

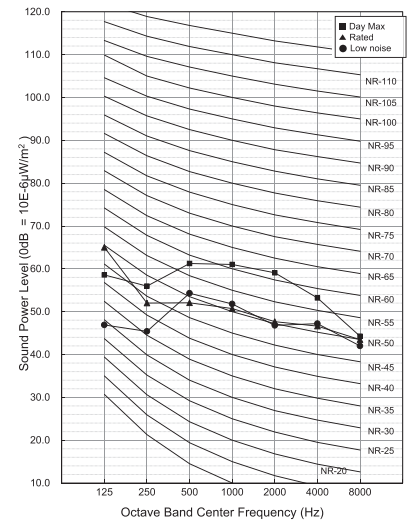

10. Hydraulic Performance

The water pump is variable type which is capable to change flow rate, so it may be required to change default water pump capacity in case of noise by water flow. In most case, however, it is strongly recommended to set capacity as Maximum.

■ Pressure Drop

◆ For GRUNDFOS Water Pump

Capacity [kW]	Rated flow-rate [LPM]	Pump Head [m] (at rated flow- rate)	Product pressure drop [m] (Plate heat exchanger)	Serviceable Head [m]	Min. flow-rate [LPM] (Recommend)
5	15.8	7.5	0.2	7.3	15
7	20.1	7.3	0.3	7.0	
9	25.9	6.1	0.4	5.7	
12	34.5	9.8	0.8	9.0	20
14	40.3	9.3	1.1	8.2	
16	46.0	9.0	1.4	7.6	

◆ For OH SUNG Water Pump

Capacity [kW]	Rated flow-rate [LPM]	Pump Head [m] (at rated flow- rate)	Product pressure drop [m] (Plate heat exchanger)	Serviceable Head [m]	Min. flow-rate [LPM] (Recommend)
5	15.8	10.9	0.2	10.7	15
7	20.1	10.7	0.3	10.4	
9	25.9	10.3	0.4	9.9	
12	34.5	9.7	0.8	8.9	20
14	40.3	9.1	1.1	8.0	
16	46.0	8.5	1.4	7.1	

Note

- To secure enough water flow rate, do not set water pump capacity as Minimum. It can lead unexpected flow rate error CH14.
- When installing the product, install additional pump in consideration of the pressure loss and pump performance.
- If flow-rate is low, overloading of product can occur.

10. Hydraulic Performance

■ GRUNDFOS Water Pump (UPM3K 20 - 75 CHBL)

◆ UN36A Chassis (5, 7, 9 kW)

Q-H Chart

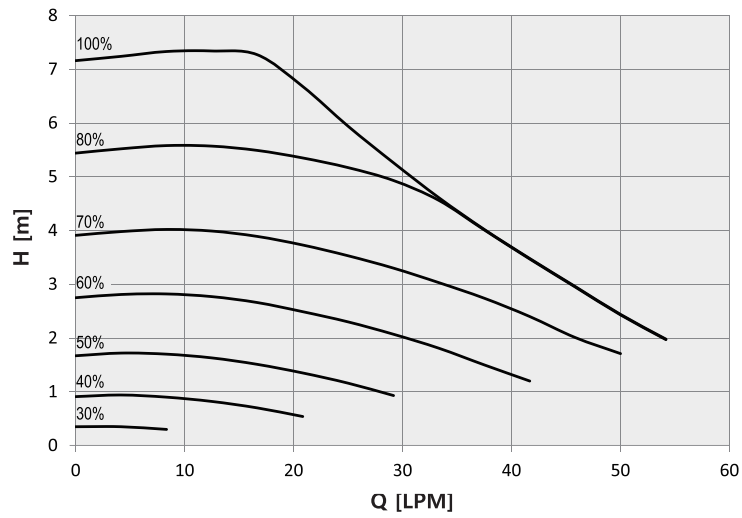

■ GRUNDFOS Water Pump (UPML 20 - 105 CHBL)

◆ UN36B Chassis (12, 14, 16 kW)

Q-H Chart

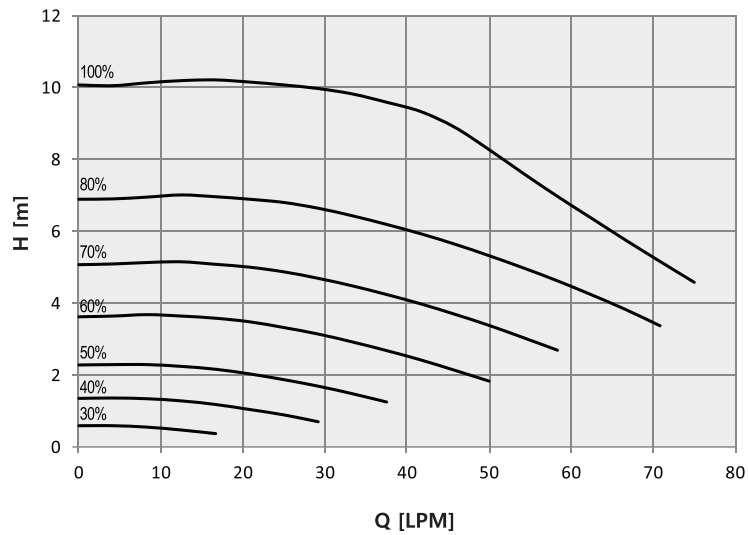

Note

Performance test based on standard ISO 9906 with pre-pressure 2.0 bar and liquid temperature 20°C.

10. Hydraulic Performance

■ OH SUNG Water Pump (ODM - 061P)

◆ UN36A Chassis (5, 7, 9 kW) / UN36B Chassis (12, 14, 16 kW)

Q-H Chart

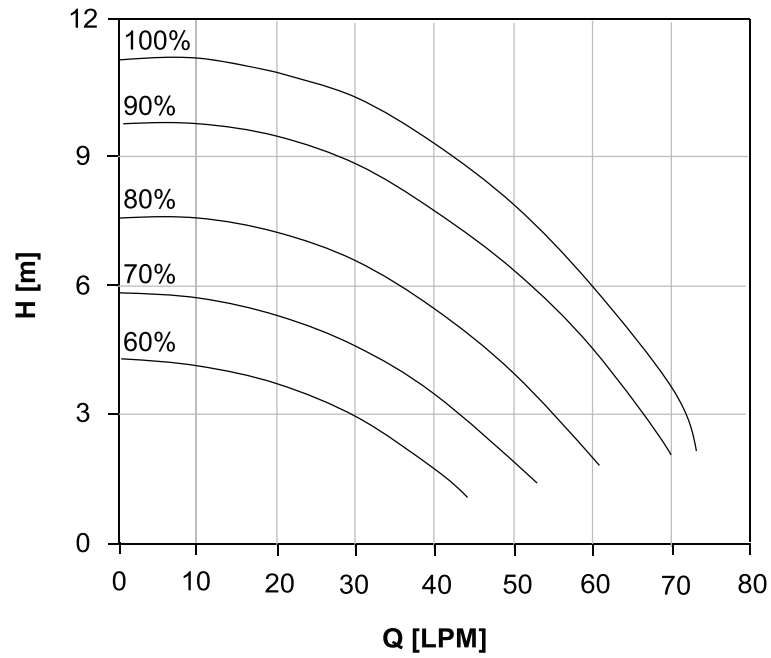

Note

Performance test based on standard ISO 9906 with pre-pressure 2.0 bar and liquid temperature 20°C.

THERMA VTM
Monobloc Type

Design and installation

- 1.Refrigerant R32**
- 2.Select the Best Location**
- 3.Foundation for Installation**
- 4.Water Control**
- 5.Water Piping System**

1. Refrigerant R32

The refrigerant R32 has the higher efficiency and more friendly for environment in comparison with R410A. It has a lower GWP (Global Warming Potential) value, and higher efficiency than R410A. The Ozone Depletion Potential (ODP) of R32 is 0, and Global Warming Potential(GWP) is 675.

Refrigerant piping consists of copper/steel pipes, joints, and other fittings. All components must be selected and installed in conformity with the standards pertaining to the Refrigeration Safety Regulation. Same piping as for R410A can be used.

WARNING

- This product contains fluorinated greenhouse gases (Refrigerant type : R32). Do NOT emit refrigerant gases into the atmosphere.
 - The refrigerant R32 is Slightly Flammable gas. But it does not leak normally. If the refrigerant leaks in the installed place and contact with burning energy, it may cause fire, or a harmful gas.
 - If there are some leak, turn off any combustible devices, ventilate the installed place, and contact the dealer from which you purchased the unit. Do not use the unit until the refrigerant leaked is repaired.
 - Only use R32 as refrigerant. Other substances may cause explosions and accidents.
-

CAUTION

- The wall thickness of the piping should comply with the relevant local and national regulations for the designed pressure.
 - For high-pressure refrigerant, any unapproved pipe must not be used.
 - Do not heat pipes more than necessary to prevent them from softening.
-

2. Selection of the best Location

2.1 Best Location

- The outdoor unit is installed outside to exchange heat with ambient air.
- Therefore, it is important to secure proper space around the outdoor unit and care for specific external conditions. This chapter presents a guide to install the outdoor unit, make a route to connect with the indoor, and what to do when installed around seaside.

- For quiet place

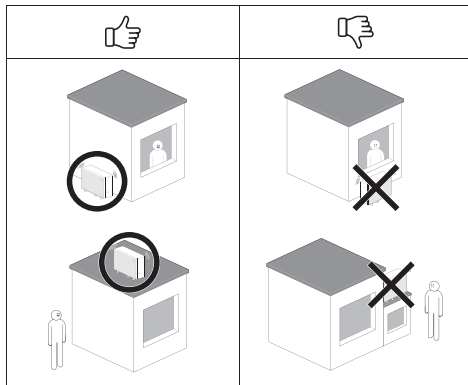

- For good ventilation

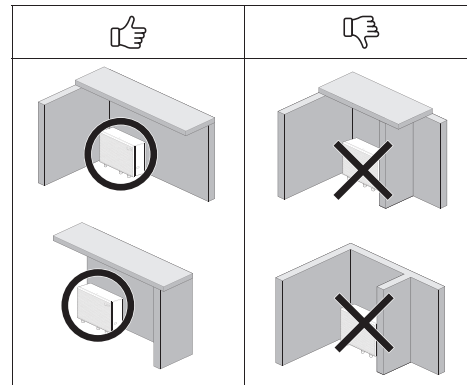

※ Please do not block the slits in the exterior panels.

- Minimum operation space

Following distances around the outdoor unit must be respected under any condition for normal operation. The distances are only for operation not to be seen as safety zone.

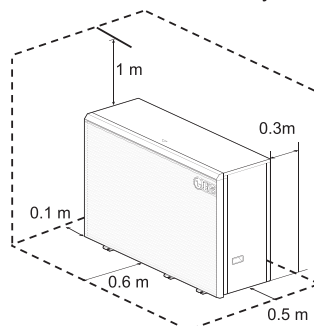

- Multiple installation

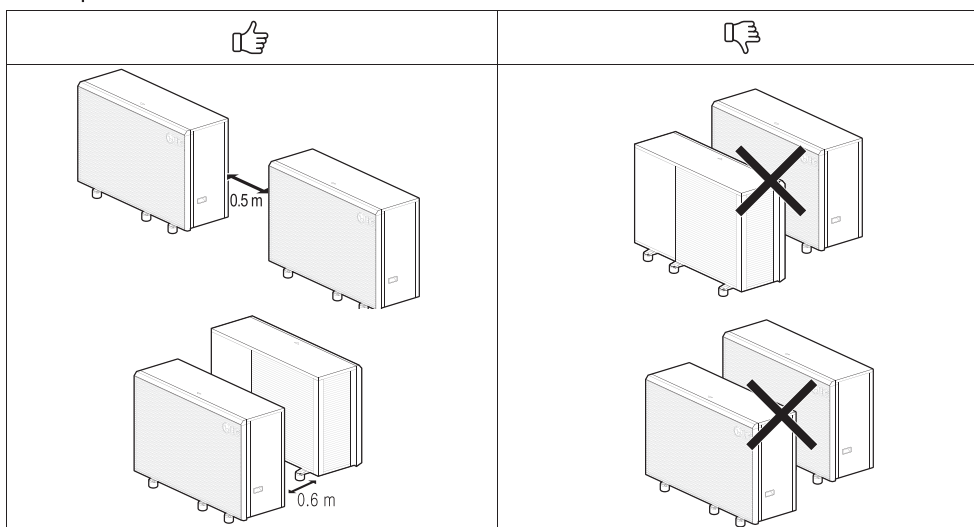

※ It can be different by model.

2. Selection of the best Location

2.2 Lifting Method

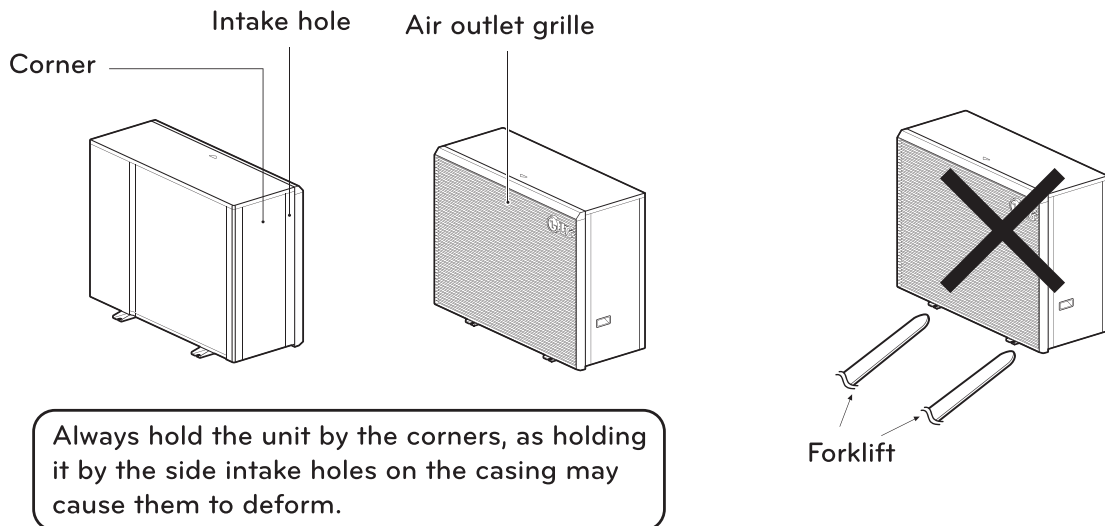
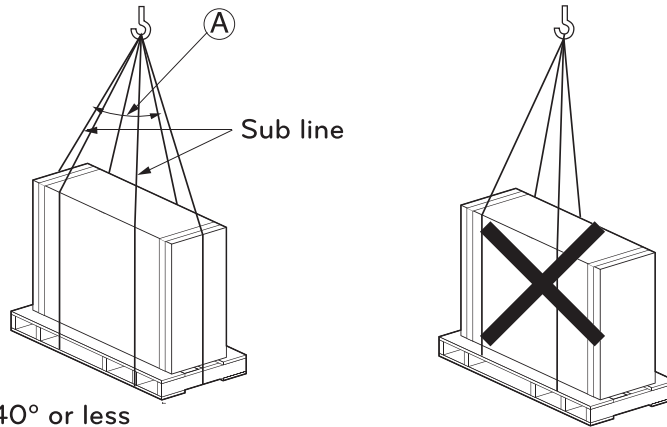

※ It can be different by model.

CAUTION

- Be very careful while carrying the product.
- PP bands are used to pack some products. Do not use them as a mean for transportation because they are dangerous.
- Do not touch heat exchanger fins with your bare hands. Otherwise you may get a cut in your hands.
- Tear plastic packaging bag and scrap it so that children cannot play with it. Otherwise plastic packaging bag may suffocate children to death.
- When carrying in Outdoor Unit, be sure to support it at four points. Carrying in and lifting with 3-point support may make Outdoor Unit unstable, resulting in a fall.
- Use 2 belts of at least 8m(26.2ft) long.
- Place extra cloth or boards in the locations where the casing comes in contact with the sling to prevent damage.
- Hoist the unit making sure it is being lifted at its center of gravity.

3. Foundation for Installation

- Check the strength and level of the installation ground so that the unit will not cause any operating vibration or noise after installation.
- Fix the unit securely by means of the foundation bolts. Prepare 6sets of M12 foundation bolts, nuts and washers available on the market.
- It is best to screw in the foundation bolts until their length are 20 mm from the foundation surface.
- When installing the unit on the ground, install a separate pedestal with enough height to install the drain nipple and higher than the average snowfall in your area.

[HM091 / 071 / 051MRS UA40] [HM161 / 141 / 121MRS UB40]

[HM163 / 143 / 123MRS UB40]

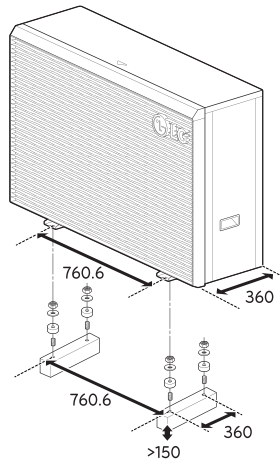

[Unit : mm]

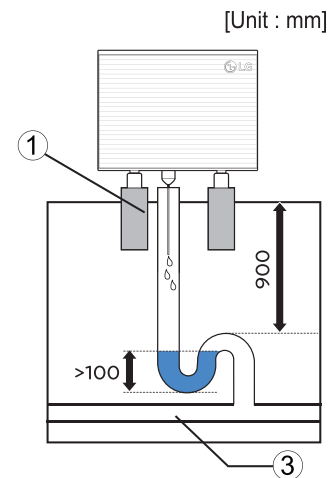
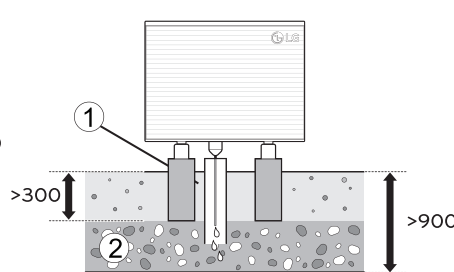
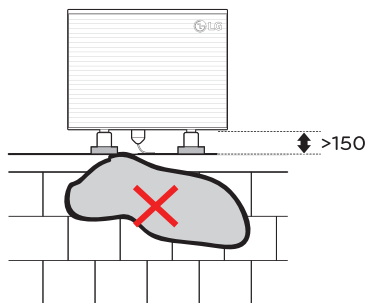
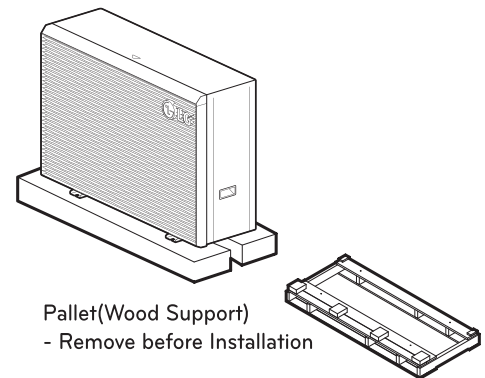
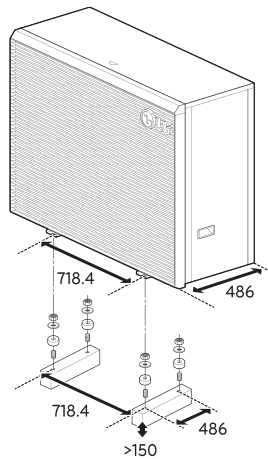

1. Section of condensate drain pipe exposed to open air must be insulated.
2. If condensate is drained into a gravel-bed, the pipe must be directed into frost-free area. The gravel must be able to absorb up to 100 ℓ of condensate per day.
3. If condensate water is drained into a rainwater sewer or other drainage pipe, note the slope of the pipe and make sure the pipe is frost-free.

⚠ CAUTION

- Do not connect to a sewer that is connected to the interior, as leaked refrigerant may enter the building.

⚠ WARNING

- Be sure that condensate does not discharge onto road to avoid accumulated freezing of condensate.

4. Water Control

4.1 Water quality

Water quality should be complied with EN 98/83 EC Directives.

CAUTION

- If the product is installed at existing hydraulic water loop, it is important to clean hydraulic pipes to remove sludge and scale.
- Installing sludge strainer in the water loop is very important to prevent performance degrade.
- Chemical treatment to prevent rust should be performed by installer.
- It is strongly recommended to install an additional filter on the heating water circuit. Especially to remove metallic particles from the heating piping, it is advised to use a magnetic or cyclone filter, which can remove small particles. Small particles may damage the unit and will NOT be removed by the standard filter of the heat pump system.
- Water quality check should be implemented before completing the installation of system.
Detailed guide can be found in the table as below.

Water contents	Value			
pH	7.5 ~ 9.0			
Conductivity	10 ~ 500 uS/cm			
TDS (Total dissolved solids)	8 ~ 400 ppm			
Alkalinity (HCO ₃ ⁻)	60 ~ 300 (mg/L)			
Total hardness	4 ~ 8.5 °dH			
	71.4 ~ 151.7 (mg/L)			
Iron (Fe)	≤ 0.2 (mg/L)			
Sulphate (SO ₄ ²⁻)	≤ 100 (mg/L)			
Nitrite (NO ₃ ⁻)	≤ 100 (mg/L)			
Free chlorine (Cl ₂)	≤ 1 (mg/L)			
Chlorides (Cl ⁻)	ppm		STS316	STS304
	pH7	15°C	3,000	180
		40°C	500	50
		60°C	200	30
		80°C	125	20
	pH9	15°C	18,000	700
		40°C	2,600	250
		60°C	1,000	170
80°C		550	130	

4. Water Control

4.2 Frost protection

In areas of the country where entering water temperatures drop below 0 °C, the water pipe must be protected by using an approved antifreeze solution. Consult your heat pump unit supplier for locally approved solutions in your area.

Calculate the approximate volume of water in the system. And add the water volume contained in the heat pump to this total volume.

Antifreeze type	Antifreeze mixing ratio (by volume)					
	0°C	-5°C	-10°C	-15°C	-20°C	-25°C
Methanol	0%	6%	12%	16%	24%	30%
Ethylene glycol	0%	12%	20%	30%	-	-
Propylene glycol	0%	17%	25%	33%	-	-

CAUTION

- Use only one of the above antifreeze.
- If a antifreeze is used, pressure drop and capability degradation of the system can be occurred.
- If one of antifreezes is used, corrosion can be occurred. So please add corrosion inhibitor.
- Please check the concentration of the antifreeze periodically to keep same concentration.
- When the antifreeze is used (for installation or operation), take care to ensure that antifreeze must not be touched.
- Ensure to respect all laws and norms of your country about antifreeze usage.

4. Water Control

4.3 Capacity correction factor by antifreeze

Antifreeze Type	Item	Antifreeze % by wt				
		10%	20%	30%	40%	50%
Methanol	Cooling	0.998	0.997	0.995	0.993	0.992
	Heating	0.995	0.990	0.985	0.979	0.974
	Pressure Drop	1.023	1.057	1.091	1.122	1.160
Ethylene glycol	Cooling	0.996	0.991	0.987	0.983	0.979
	Heating	0.993	0.985	0.977	0.969	0.961
	Pressure Drop	1.024	1.068	1.124	1.188	1.263
Propylene glycol	Cooling	0.993	0.987	0.980	0.974	0.968
	Heating	0.966	0.973	0.960	0.948	0.935
	Pressure Drop	1.040	1.098	1.174	1.273	1.405

◆ Correction factor of cooling capacity

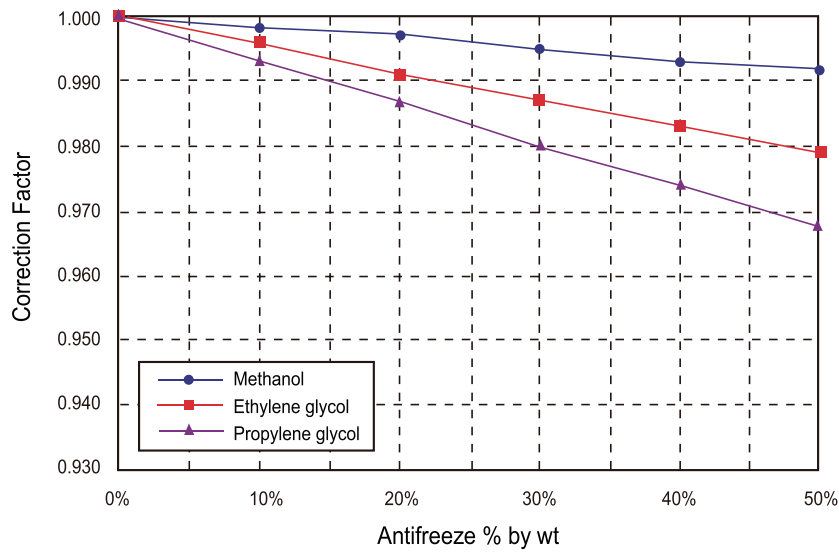

◆ Correction factor of heating capacity

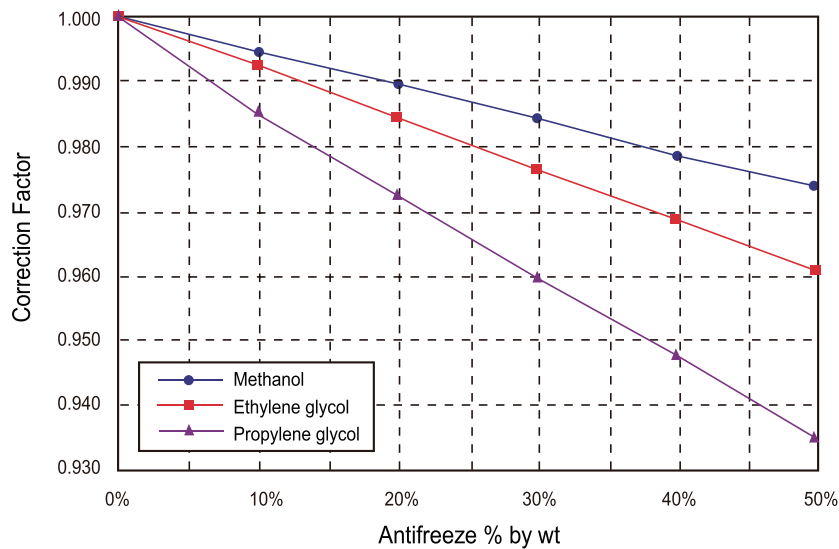

5. Water Piping System

5.1 Water Piping and water Circuit Connection

5.1.1 General considerations

- Followings are should be considered before beginning water circuit connection.
- Service space should be secured.
- Water pipes and connections should be cleaned using water.
- Space for installing external water pump should be provided if internal water pump capacity is not enough for installation field.
- Never connect electric power while proceeding water charging.

5.1.2 Water piping and water circuit connection

1. Definition of terms are as follow :

- Water piping : Installing pipes where water is flowing inside the pipe.
- Water circuit connecting : Making connection between the unit and water pipes or between pipes and pipes. Connecting valves or elbows are, for example, in this category.
- A buffer tank should be installed to reduce sudden load fluctuations. (Please refer to the product installation manual guide)

2. While installing water pipes, followings should be considered :

- While inserting or putting water pipes, close the end of the pipe with pipe cap to avoid dust entering.
- When cutting or welding the pipe, always be careful that inner section of the pipe should not be defective. For example, no weldments or no burrs are found inside the pipe.
- Drain piping should be provided in case of water discharge by the operation of the safety valve. This situation can be happened when the internal pressure is over 3.0 bar and water inside the unit will be discharged to drain hose.

3. While connecting water pipes, followings should be considered :

- Pipe fittings (e.g. L-shape elbow, T-shape tee, diameter reducer, etc) should be tightened strongly to be free from water leakage.
- Connected sections should be leakage-proof treatment by applying teflon tape, rubber bushing, sealant solution, etc.
- Appropriate tools and tooling methods should be applied to prevent mechanical breakage of the connections.
- Operation time of flow control valve(e.g. 3way valve or 2way valve) should be less than 90 seconds.
- Drain hose should be connected with drain piping.

WARNING

• Water condensation on the floor

If underfloor cooling is performed, it is very important to keep leaving water temperature higher than 16 °C. Otherwise, dew condensation can occur on the floor. If floor is in humid environment, do not set leaving water temperature below 18 °C.

• Water condensation on the radiator

While cooling operation, cold water may not flow to the radiator. If cold water enters to the radiator, dew generation on the surface of the radiator can be occurred. Use 2way-valve to block circuits from cooling operation.

• Drainage

While cooling operation, condensed dew can drop down to the bottom of the unit. The condensing water must be sufficiently drained from the unit and dissipated frost-free.



Air Solution
LG Electronics Inc, 128, Yeoui-daero,
Yeongdeungpo-gu, Seoul, Korea
(07336)
<http://partner.lge.com>

Copyright© 2021-2024 LG Electronics Inc.
All Rights Reserved.
Printed in Korea June / 2024

The air conditioners manufactured by LG have received ISO9001 certificate for quality assurance and ISO14001 certificate for environmental management system.
The specifications, designs, and information in this brochure are subject to change without notice.