

innova
something new in the air

User manual

2.0

We would first of all like to thank you for having chosen one of our appliances.

We are sure you will be happy with it because it represents the state of the art in the technology of home air conditioning.

By following the suggestions contained in this manual, the product you have purchased will operate without problems, giving you optimum room temperatures with minimum energy costs.

Innova S.r.l

This booklet code N273027A - Rev. 0 - (03/13) consists of 12 pages.

Compliance

This unit complies with European directives:

- Low voltage 2006/95/EC
- Electro-magnetic compatibility 2004/108/EC
- Use restrictions of hazardous substances in electrical and electronic equipment 2011/65/EC (RoHS2)
- Waste electrical and electronic equipment 2002/96/EC (WEEE).
- Energy consumption indication on the labels of energy-related products 2010/30/EU

Symbols

Pictograms in the next chapter provide the necessary information for a correct and safe use of the machine in a

rapid, unmistakable way.

Editorial pictograms

U User
- Refers to pages containing instructions or information for the user.

I Installer
- Refers to pages containing instructions or information for the installer.

S Service
- Refers to pages containing instructions or information for the CUSTOMER TECHNICAL ASSISTANCE SERVICE installer.

Safety pictograms

⚠ Warning
- It indicates actions that require caution and a suitable preparation.

⊘ Do Not
- Refers to actions that absolutely must not be performed.

USER MANUAL

1.1 Warning

- ⚠ The installation and all electrical connections must be carried out by specialised personnel in compliance with the law. Installation instructions are explained in the specific paragraph of this manual.
- ⚠ Objects or structural obstacles (furniture, curtains, plants, leaves, blinds, etc.) must not obstruct the normal air flow both from the internal and from the external grids.
- ⚠ Do not lean or sit on the air conditioner to avoid serious damage to its external parts.
- ⚠ Do not move the horizontal air outlet flap manually. Always use the remote control to perform such operation.
- ⚠ In the event of water leaks, turn off the appliance and disconnect the electric power supply. Call the nearest service centre.
- ⚠ During heating mode, the conditioner eliminates periodically any ice formed on the external battery. In such situation, the machine keeps on working but it does not dispense warm air to the room. This phase can last 3 up to maximum 10 minutes.
- ⚠ The appliance must not be installed in rooms where explosive gases develop or where there are humidity and temperature conditions that exceed the maximum levels reported on the installation manual.
- ⚠ Clean the air filter regularly as described in the specific paragraph.

1.2 Management of the appliance with the touch-screen display

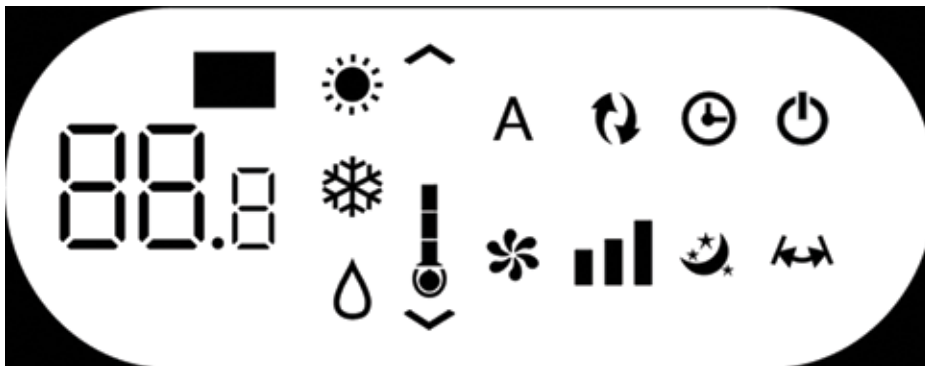

Normally, the display shows the operating status (see Description of machine functioning paragraph) as well as any alarms (see Display alarms paragraph).

In addition, it is possible to select the various functions by

pressing the symbols.

1.3 Managing the appliance with the remote control



It is possible to select the various modes by pressing the buttons (see Description of machine functioning paragraph).

⚠ The remote control provided has been designed to be functional and resistant, however it must be handled cautiously.

Avoid:

- leaving it exposed to rain, pouring liquids on it or dropping it into water
- hitting it or dropping it on hard surfaces
- leaving it under the sun

- placing obstacles between the remote and the appliance while using it.

In addition:

- if there are other appliances using remote controls in the room (TV, radios, stereos, etc.), interferences may occur
- electronic or fluorescent lamps can interfere with communication between the remote and the appliance
- remove the battery if not using the remote for a long time.

Battery insertion

Only CR2012 3V dry lithium batteries must be used (supplied). Used batteries must be handed over to the specific collection areas as arranged by the Local Authorities for this type of waste. In order to insert the batteries, open the specific cover

in the bottom part of the remote. The battery must be inserted respecting polarity. Once the battery is inserted, close the cover.

1.4 Description of machine functioning













General start-up and management







In order to manage the appliance using the remote control and the touch-screen, the main switch on the electrical power supply line must be turned on (its exact position will be best known by the technician who installed the appliance) or the power supply plug must be connected to the system socket.

Once such operations have been performed, it is possible to manage the system using the symbols on the touch-screen or the remote control. In order to transmit commands to the internal unit, the top part of the remote must point towards the display of said internal unit. The reception of the command is confirmed by a beep and by the display. The maximum distance for the remote control to work is approximately 8 metres.

Once such operations have been performed, it is possible to manage the system using the symbols on the touch-

Key/Display	Operation
⚠	The buttons on the remote and the keys on the touch-screen display have the same function.
88.8	When the appliance is on, 3 digits on the display will show the room temperature.
⬆	<ul style="list-style-type: none"> • It is possible to adjust the setpoint between 16 and 31°C.
⬇	⚠ Avoid setting the temperature too low or too high as, in addition to being unhealthy, it's a waste of energy.

Key/Display	Operation
	<p>Switching the appliance on and off</p> <p>It is possible to switch the appliance on or off (stand-by) by pressing the specific button. The control system of the appliance is equipped with a memory, so settings won't be lost if the appliance is switched off or in the event of low voltage. The button must be used to activate or deactivate the appliance for short periods of time.</p> <p> In case of long periods of inactivity, the appliance must be deactivated disconnecting either the main switch or the plug from the socket.</p>
	<p>Well-being button (economic automatic mode)</p> <p>By choosing this mode on the appliance, it is set so as to obtain the best level of comfort in the room. The conditioner selects the mode automatically (cooling or heating) according to the temperature set and ventilation speed according to the temperature of the room.</p>
	<p>Cooling only mode</p> <ul style="list-style-type: none"> In this mode, the appliance dehumidifies and cools the room.
	<ul style="list-style-type: none"> It is possible to set the desired temperature between 16 and 31°C and, if such temperature is lower than the room temperature, the compressor starts up after three minutes (maximum) and the appliance starts dispensing cool air, maintaining ventilation active even if the setpoint has been reached.
	<p>Dehumidification only mode</p> <p>In this mode, the appliance dehumidifies the room. Selecting this mode is useful during mid-seasons, that is to say during those days (e.g. rainy ones) when the temperature is rather pleasant, but excess humidity causes discomfort. This mode ignores both room temperature and ventilation speed settings. The latter is always set to a minimum. It is normal for the appliance to work intermittently.</p>
	<p>Ventilation only mode</p> <p>By selecting this mode, the compressor is not activated and the appliance does not intervene on room temperature or humidity. It is possible to choose the fan speed.</p>
	<p>Heating only mode</p> <ul style="list-style-type: none"> In this mode, the appliance heats the room. <p> Set on heating only mode, the appliance defrosts the evaporative battery periodically if necessary. During this phase, the conditioner does not dispense warm air, even if its internal organs are on except for air ventilation.</p>
	<ul style="list-style-type: none"> It is possible to set the desired temperature between 16 and 31°C and, if such temperature is higher than the room temperature, the compressor starts up after three minutes (maximum) and the appliance starts dispensing warm air.
	<p>Nocturnal well-being button</p> <p>While the appliance is on in the selected cooling or heating mode, it is possible to choose different functions by pressing the button in order to maximise noise reduction, energy saving and nocturnal well-being regulation. In this mode, ventilation is set on minimum speed. This mode should be activated right before going to sleep.</p> <ul style="list-style-type: none"> In cooling mode, the set temperature is risen by 1°C after one hour and by another degree after two. After the second hour, the temperature is no longer changed and, after six hours, the appliance is put in stand-by. In heating mode, the set temperature is lowered by 1°C after one hour and by another degree after two. After the second hour, the temperature is no longer changed and, after six hours, the appliance is put in stand-by. <p>This function is not available for dehumidification only, ventilation only and economic automatic modes and can be excluded any time (ideally once awake) by pressing the button again. If the Timer has also been set, the appliance will turn off at the set time.</p>
	<p>Control of air flow direction</p> <p>By pressing the specific button, it is possible to select the continuous oscillation of the mobile air outlet flap - in such case, the symbol on the display is lit - or to block it in any position.</p> <p> IMPORTANT: The mobile flap must never be moved manually.</p>

Key/Display	Operation
	<p>Fan speed control</p> <p>By pressing this button, the speed changes according to the following sequence: Minimum, Medium, Maximum and Automatic.</p> <p>The higher the speed, the better the performance, though the appliance will be more noisy. By selecting the Automatic speed (which can be visualised by sliding the 3 speed bars on the display), the microprocessor regulates the speed automatically, increasing or decreasing it according to the difference between the room temperature and the set temperature. It is not possible to control the speed while in dehumidification only and nocturnal well-being mode, as the appliance can only work in low speed.</p>
	<p>Timer mode setting</p> <ul style="list-style-type: none"> The appliance offers Users the chance to programme its activation and deactivation according to their needs.
	<ul style="list-style-type: none"> While the conditioner is on, it is possible to programme the switch-off time by pressing the Timer button and setting the number of hours (1 to 24) after which the appliance will be put in stand-by. When the conditioner is off, it is possible to programme the switch-on time by pressing the Timer button and setting the number of hours (1 to 24) after which the appliance will start-up.
	
	<ul style="list-style-type: none"> Press the button to confirm.
	<p>Touch-screen display key lock</p> <ul style="list-style-type: none"> The key lock is activated by keeping the Timer symbol on the touch-screen display pressed for three seconds. Any action is prevented by the user. The stand-by symbol flashes at 1 second intervals. To deactivate the lock, keep the Timer symbol pressed for three seconds again. <p> Any key on the remote control deactivates the lock!</p>

Managing the appliance if the remote control is not available

If you lose the remote control, if it brakes or if the batteries run out, the appliance can be managed using the touch-screen display.

1.5 Advice for energy saving

- Always keep filters clean (see Maintenance and Cleaning chapter).
- Keep doors and windows closed
- Avoid direct sunlight in the room (use curtains, pull down the blinds or close the shutters)
- Do not obstruct the air flow (inwards and outwards)

as, on top of affecting performance, it prevents the system from working correctly and it may cause irreparable damage to the appliance.

1.6 Problem diagnosis

It is very important that the User is capable of distinguishing problems or anomalies from normal functioning. The most common problems can be solved by the User following simple procedures (see Troubleshooting paragraph), whereas it is necessary to contact the Service Centre for some of the alarms.

 We would like to remind you that any reparation attempt performed by unauthorised personnel immediately invalidates any warranty.

Operating aspects that must not be interpreted as problems

- The compressor does not start again before a certain period of time (approximately 3 minutes from the previous stop). The delay between stops and reactivations has been arranged in order to protect the compressor from too frequent activations.
- During heating mode, it is possible that warm air is dispensed a few minutes after the compressor has been activated. If the fan were to start together with the compressor, cold air would be dispensed to the room (which could lead to discomfort for those in the room) as the appliance is not fully operational yet.

Troubleshooting

In case of malfunctioning, please refer to the following table. If, after performing the suggested checks, the problem is not solved, please contact the authorised technical assistance.

Anomaly	Possible cause	Solution
The appliance doesn't switch on	No power supply	Check the voltage (by turning the light on, for example). Check that the exclusive magneto-thermic switch that protects the appliance hasn't intervened (if it has, reset it). If the problem repeats immediately, please call the Service Centre and avoid trying to make the appliance work.
	Batteries ran out	Check that the appliance can be turned on using the touch-screen display and substitute the batteries.
The appliance does not cool/heat enough.	The temperature set is too high or too low.	Check and adjust the temperature.
	The air filter is clogged	Check the air filter and clean it if necessary
	Check that there are no other obstacles of the air flow both inside and outside.	Remove anything that might block the air flow.
	The thermal refrigeration load has increased (for example, a door or a window has been left open or an appliance has been installed in the room which generates a lot of heat).	Try to reduce the thermal refrigeration load of the room following instructions below: Cover large windows exposed to sunlight with curtains or with external maskings (blinds, porches, reflecting films, etc.); The room must remain closed for as long as possible; Avoid using halogen lamps or other high energy consumption appliances such as small ovens, steam irons, cooking plates etc.

Display alarms

An alarm code appears on the display in case of anomalies. Some of the functions remain active nonetheless (see FUNCTIONING column).

Alarm displayed	Cause	Functioning
E1	Broken room temperature RT sensor	It is still possible to activate the Cooling, Dehumidification and Heating modes. It only monitors the antifreeze function of the internal battery.
E2	Broken internal battery IPT sensor	It is still possible to activate the Cooling, Dehumidification and Heating modes.
E3	Broken outside temperature OT sensor	It is still possible to activate the Cooling, Dehumidification and Heating modes.
E4	Broken outside battery OPT sensor	It is still possible to activate the Cooling, Dehumidification and Heating modes. Defrosting is performed at fixed times.
E5	Broken internal fan motor	None of the modes can be activated.
E6	Broken external fan motor	None of the modes can be activated.
E7	Lack of communication with the display	None of the modes can be activated.
CP	Open CP contact	The appliance only works if the contact is closed. Check that the clamps are connected.
OF	Maximum level float intervention	During cooling and dehumidification, electronics switches the compressor off and keeps the water distribution system active with the battery - together with the fan - to disperse excess water. During heating, condensations should drain freely through the specific pipe. In the event of an alarm, check that the condensation pipe is not bent or obstructed, thus preventing the water from flowing out.

The only way to solve the problem is to disconnect and reconnect the appliance. If the alarm still appears, please contact the authorised technical assistance.

1.7 Technical data

Please read data plate to obtain the technical data listed below.

- Power supply voltage
- Maximum absorbed power
- Maximum absorbed current
- Amount of refrigerant gas
- Casing protection level
- Max. working pressure

	U.M.	"2.0" 8 HP	"2.0" 10 HP
Technical data			
Cooling power (1)	kW	1.65	2.30
Heating power (2)	kW	1.70	2.25
Power absorbed when cooling (1)	W	580	850
Power absorbed when heating (2)	W	545	725
Annual energy consumption for cooling (1)	kWh	290	425
Dehumidification capacity	l/h	0.8	1.1
Power supply voltage	V-F-Hz	230-1-50	230-1-50
EER	W/W	2.84	2.71
COP	W/W	3.12	3.1
Energy efficiency ratio when cooling		A	A
Energy efficiency ratio when heating		A	A
Internal-external ventilation speed	No.	3	3
Dimensions (WxHxD)	mm	1030x555x170	1030x555x170
Weight	Kg	46	48
Noise level (min-max)*	dB(A)	29/38	32/41
Wall holes diameter	mm	162	162
Refrigerant gas		R-410A	R-410A
Minimum cooling temperatures (internal/external, DB)		18°C/-5°C	18°C/-5°C
Minimum heating temperatures (internal/external, DB)		5°C/-10°C	5°C/-10°C

Operating limits

	Room t	External t
Test conditions		
Cooling mode tests (1)	DB 27°C - WB 19°C	DB 35°C - WB 24°C
Heating mode tests (2)	DB 20°C - WB 15°C	DB 7°C - WB 6°C

* Noise pressure measured 1 m away and 1.5 m high

Relevant regulation EN 14511. 1. 2.3.4

1.8 Periodic Maintenance

The air conditioner you have bought has been designed to keep maintenance operations to a minimum, in fact, they

only include the following cleaning operations.

External cleaning

- ⚠ Before any cleaning and maintenance operation, disconnect the unit from the mains by switching off the main switch.
- ⚠ Wait until the parts have cooled down to avoid getting burned.

- ⚠ Do not use abrasive sponges or abrasive or corrosive detergents to avoid damaging varnished surfaces.

When necessary, clean the external surfaces with a soft damp cloth.

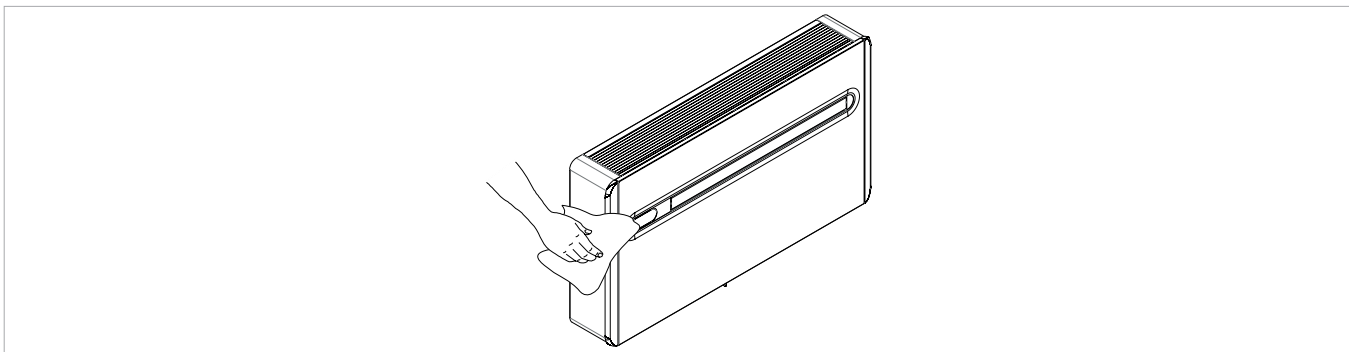

Cleaning filtering seats

The air conditioner you have bought has been designed to keep maintenance operations to a minimum, in fact, they only include the following cleaning operations:

- Clean the air filter after a period of continuous use and according to the concentration of impurities in the air, or when you wish to start-up the appliance after a period of inactivity. The filter is placed in the top part of the appliance.

To extract the filters:

- open the grid and remove it;
- extract the filters by lifting them;
- remove the dust from the filter with a vacuum cleaner or by washing it in running water without using detergents or solvents and leave to dry;
- put the filters back on top of the batteries, taking care to position them correctly;
- put the grid back.

- ⚠ Check that the panel is mounted correctly after cleaning operations.

- ⊘ Using the appliance without the net filters is prohibited

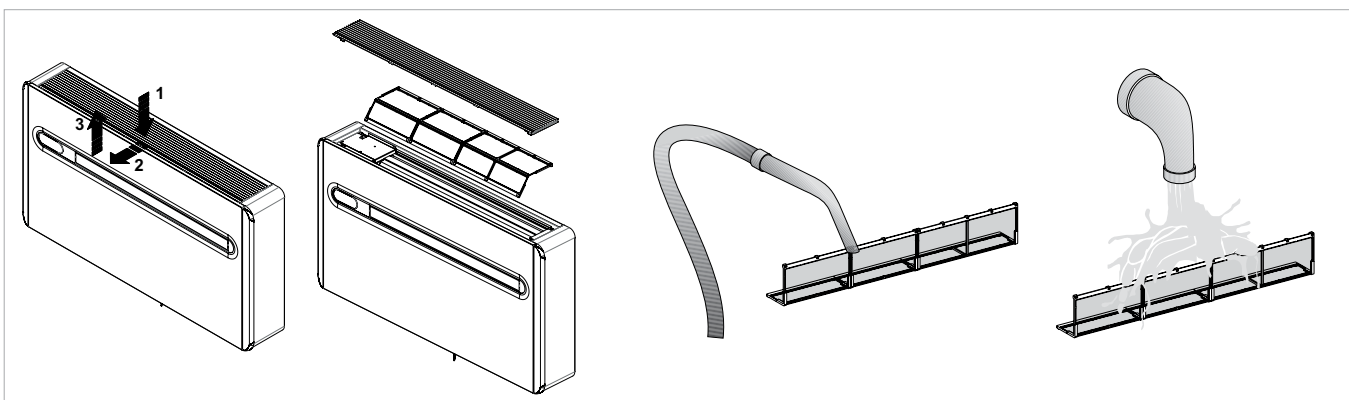

INNOVA s.r.l.
Fraz . Strada, 16 - 38085 PIEVE DI BONO (TN) - ITALY
tel. +39.0465.670104 fax +39.0465.674965
info@innovaenergie.com

N273027A - Rev. 0